

Cobra®

Gas Griddle Toaster

Model CT6

INSTALLATION AND OPERATION MANUAL

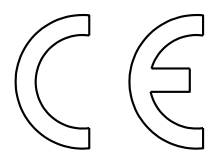

For use in GB & IE

MANUFACTURED BY

Moffat Limited

Christchurch
New Zealand

INTERNATIONAL CONTACTS

AUSTRALIA

Moffat Pty Limited

E.Mail: vsales@moffat.com.au
Main Office: (tel): +61 (03) 9518 3888
(fax): +61 (03) 9518 3833
Service: (tel): 1800 622 216
Spares: (tel): 1800 337 963
Customer Service: (tel): 1800 335 315
(fax): 1800 350 281

CANADA

Serve Canada

Web: www.servecanada.com
E.Mail: info@servecanada.com
Sales: (tel): 800 551 8795 (Toll Free)
Service: (tel): 800 263 1455 (Toll Free)

NEW ZEALAND

Moffat Limited

Web: www.moffat.co.nz
E.Mail: sales@moffat.co.nz
Main Office: (tel): 0800 663328

UNITED KINGDOM

Blue Seal

Web: www.blue-seal.co.uk
E.Mail: sales@blue-seal.co.uk
Sales: (tel): +44 121 327 5575
(fax): +44 121 327 9711
Spares: (tel): +44 121 322 6640
(fax): +44 121 327 9201
Service: (tel): +44 121 322 6644
(fax): +44 121 327 6257

UNITED STATES

Moffat

Web: www.moffat.com
Sales: (tel): 800 551 8795 (Toll Free)
(tel): +1 336 661 1556
(fax): +1 336 661 9546
Service: (tel): 800 858 4477 (Toll Free)
(tel): +1 366 661 1556
(fax): +1 336 661 1660

REST OF WORLD

Moffat Limited

Web: www.moffat.co.nz
E.Mail: export@moffat.co.nz

The reproduction or copying of any part of this manual by any means whatsoever is strictly forbidden unless authorized previously in writing by the manufacturer.

In line with policy to continually develop and improve its products, Moffat Ltd. reserves the right to change the specifications and design without prior notice.

© Copyright Moffat Ltd. August 2011.

Contents

CT6 Gas Griddle Toaster

Part 1	Introduction	2
Part 2	Specifications	3
Part 3	Installation	4
Part 4	Operation	7
Part 5	Cleaning and Maintenance	8
Part 6	Gas Conversion	10
Part 7	Replacement Parts List	13

Part 1 Introduction

We are confident that you will be delighted with your **Cobra Series** Gas Griddle Toaster, and it will become a most valued appliance in your commercial kitchen.

To ensure you receive the utmost benefit from your new **Cobra Series** Appliance, there are two important things you can do.

Firstly:

Please read this instruction book carefully and follow the directions given. The time taken will be well spent.

Secondly:

If you are unsure of any aspect of the installation, instructions or performance of your appliance, contact your **Cobra Series** appliance dealer promptly. In many cases a phone call could answer your question.

CE Only:

These instructions are only valid if the country code appears on the appliance. If the code does not appear on the appliance, refer to the supplier of this appliance to obtain the technical instructions for adapting the appliance to the conditions for use in that country.

WARNING:

IMPROPER INSTALLATION, ADJUSTMENT, ALTERATION, SERVICE OR MAINTENANCE CAN CAUSE PROPERTY DAMAGE, INJURY OR DEATH. READ THE INSTALLATION, OPERATING AND MAINTENANCE INSTRUCTIONS THOROUGHLY BEFORE INSTALLING OR SERVICING THIS APPLIANCE.

WARNING:

INSTRUCTIONS TO BE FOLLOWED IN THE EVENT THE USER SMELLS GAS ARE TO BE POSTED IN A PROMINENT LOCATION. THIS INFORMATION SHALL BE OBTAINED BY CONSULTING THE LOCAL GAS SUPPLIER.

WARNING:

GREAT CARE MUST BE TAKEN BY THE OPERATOR TO USE THE EQUIPMENT SAFELY TO GUARD IT AGAINST RISK OF FIRE.

- THE APPLIANCE MUST **NOT** BE LEFT ON UNATTENDED.
- IT IS RECOMMENDED THAT A REGULAR INSPECTION IS MADE BY A COMPETENT SERVICEMAN TO ENSURE CORRECT AND SAFE OPERATION OF YOUR APPLIANCE IS MAINTAINED.
- **DO NOT** STORE OR USE GASOLINE OR OTHER FLAMMABLE VAPOURS OR LIQUIDS IN THE VICINITY OF THIS OR ANY OTHER APPLIANCE.
- **DO NOT** SPRAY AEROSOLS IN THE VICINITY OF THIS APPLIANCE WHILE IT IS IN OPERATION.

CAUTION:

This appliance is;

- For professional use and is to be used by qualified persons only.
- Only Qualified service persons are to carry out installation, servicing and gas conversion operations.
- Components having adjustments protected (e.g. paint sealed) by the manufacturer should not be adjusted by the user / operator.
- **DO NOT** operate the appliance without the legs supplied fitted.

Part 2 Specifications

Model Covered in this Specification -
CT6 Gas Griddle Toaster.

General

A commercial heavy-duty gas fired griddle toaster, having two tubular burners heating a griddle plate from underneath and providing toasting heat for the toasting rack below.

Burners are operated by individual control valves and are provided with a piezo ignition permanent pilot incorporating a thermocouple flame failure control.

Gas Supply Requirements

- Non - UK Only:

	Natural Gas	LP Gas (Propane)
Input Rating (N.H.G.C.)	42 MJ/hr (39,800 Btu/hr)	42 MJ/hr (39,800 Btu/hr)
Supply Pressure	1.13 - 3.40 kPa (4.5" - 13.5" w.c.)	2.75 - 4.50 kPa (11" - 18" w.c.)
Burner Operating Pressure	1.00 kPa (*) (4.0" w.c.)	2.50 kPa (*) (10.0" w.c.)
Gas Connection	1/2" BSP Male	

- UK Only:

		Nat Gas (G20)	Propane (G31)
Heat Input (nett)	Nominal	11.0 kW	11.0 kW
	Reduced	6.0 kW	5.6 kW
Gas Rate (nett)	Nominal	1.16 m ³ /hr	0.85 kg/hr
	Reduced	0.63 m ³ /hr	0.44 kg/hr
Supply Pressure		20 mbar	37 mbar
Burner Operating Pressure		10 mbar (*)	26 mbar (*)
Gas Connection		1/2" BSP Male	

NOTE: (*)

The burner operating pressure is to be measured at the manifold test point with all burners operating at full setting. The operating pressure is ex-factory set, through the appliance regulator and is not to be adjusted, apart from when converting between gases, if required. (Refer to the 'Gas Conversion' Instruction Sheet' for this appliance for further details).

Gas Connection

Gas supply connection point is located 130 mm from the right hand side of the appliance, 32 mm from the rear and 655 mm from the floor and is entered from beneath the appliance.

Connection is 1/2" BSP male.

Dimensions

CT6 Gas Griddle Toaster (600 mm)

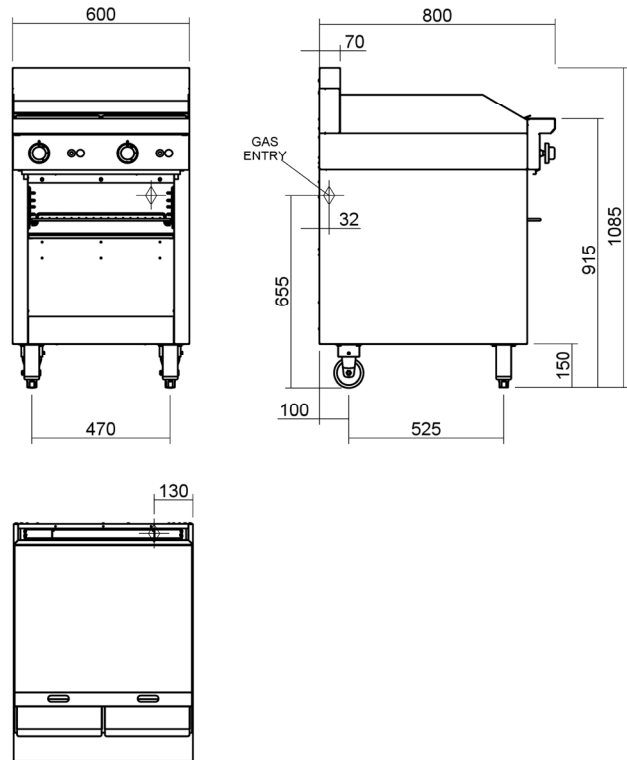

Installation Requirements

NOTE:

It is most important that this appliance is installed correctly and that operation is correct before use. Installation shall comply with local, gas, health and safety requirements.

This appliance shall be installed with sufficient ventilation to prevent the occurrence of unacceptable concentrations of health harmful substances in the room, the appliance is installed in.

Cobra Series Gas Griddle Toasters are designed to provide years of satisfactory service and correct installation is essential to achieve the best performance, efficiency and trouble-free operation. This appliance must be installed in accordance with National installation codes and in addition, in accordance with relevant National / Local codes covering gas and fire safety.

Australia:

AS 5601 - Gas Installations.

New Zealand:

NZS 5261 - Gas Installation.

United Kingdom:

Gas Safety (Installation and Use) Regulations 1998.

BS6173 - Installation of catering Appliances.

BS5440 - 1 & 2 Installation Flueing & Ventilation.

Ireland:

IS 820 - Non Domestic Gas Installations.

Installations must be carried out by qualified service persons only. Failure to install equipment to the relevant codes and manufacturer's specifications shown in this section will void the warranty.

Components having adjustments protected (e.g. paint sealed) by manufacturer, are only to be adjusted by an qualified service agent. They are not to be adjusted by the installation person.

Unpacking

- Remove all packaging and transit protection from the appliance including all protective plastic coating from the door outer panel and exterior stainless steel panels.
- Check equipment and parts for damage. Report any damage immediately to the carrier and distributor.
- Report any deficiencies to the distributor who supplied the appliance.
- Check that the available gas supply is correct to that shown on the rating plate located on the right hand side panel, beneath the middle shelf.

- Check that the following parts have been supplied with the appliance:

Enamelled Crumb Tray	1
Toasting Rack	1
Toasting Rack Tray (St/Steel)	1
Grease Drawer	1
Adjustable Legs	4
Gas Regulator	1

Location

1. Installation must allow for a sufficient flow of fresh air for the combustion air supply.

Combustion Air Requirements

Natural Gas	10 m ³ /hr minimum.
LPG / Propane	9 m ³ /hr minimum.

2. Installation must include adequate ventilation means, to prevent dangerous build up of combustion products.
3. Position the appliance in its approximate working position.
4. All air for burner combustion is supplied from underneath the appliance. The legs must always be fitted and no obstructions placed on the underside or around the base of the appliance, as obstructions will cause incorrect operation and / or failure of the appliance.
5. Components having adjustments protected (e.g. paint sealed) by manufacturer are only to be adjusted by a qualified service agent. They are not to be adjusted by the installation person.

NOTE:

Do not obstruct or block the appliances flue. Never directly connect a ventilation system to the appliance flue outlet.

Clearances

NOTE:

Only non-combustible materials can be used in close proximity to this appliance.

Any gas burning appliance requires adequate clearance and ventilation for optimum and trouble-free operation. The following minimum installation clearances are to be adhered to:

	Combustible Surface	Non Combustible Surface
LH / RH Side	50 mm	0 mm
Rear	50 mm	0 mm

Assembly

This model is delivered completely assembled. Ensure that the legs are securely attached.

NOTE:

This appliance is fitted with adjustable feet to enable the appliance to be positioned securely and level. This should be carried out on completion of the gas connection. Refer to the 'Gas Connection' section.

Gas Connection

NOTE:

ALL GAS FITTING MUST ONLY BE CARRIED OUT BY A QUALIFIED SERVICE PERSON.

1. **Cobra Series** Gas Griddle Toasters do not require an electrical connection, they function totally on the gas supply only.
2. It is essential that the gas supply is correct for the appliance to be installed and that adequate supply pressure and volume are available. The following checks should be made before installation:-
 - a. **The Gas Type** the appliance has been supplied for is shown on coloured stickers located above the gas entry point and next to the rating plate. Check that this is correct for the gas supply the appliance is being installed for. The gas conversion procedure is detailed in the Gas Conversion Instruction Sheet for this appliance.
 - b. **Supply Pressure** required for this appliance is shown in the 'Specifications' section of this manual. Check the gas supply to ensure that adequate supply pressure exists.
 - c. **Input Rate** of this appliance is also stated on the Rating Plate fitted to the inside of the right hand side panel, below the middle shelf and in the 'Specifications' section of this manual. The input rate should be checked against the available gas supply line capacity. **Particular note should be taken if the appliance is being added to an existing installation.**

NOTE:

It is important that adequately sized piping runs directly to the connection joint on the appliance, with as few tees and elbows as possible to give maximum supply volume.

3. Fit the gas regulator supplied, into the gas supply line as close to the appliance as possible.

NOTE:

The gas pressure regulator provided with this appliance is convertible between Natural Gas and LPG as per the 'Gas Conversion Section' in this manual.

Ensure the regulator is converted to the correct gas type that the appliance will operate on.

The regulator outlet pressure is fixed ex-factory for the gas type that the regulator is converted to and it is NOT to be adjusted.

The regulator connections are 1/2" BSP female.

The connection to the appliance is 1/2" BSP male.

(Refer to the 'Specifications' section for the gas supply location dimensions).

NOTE:

A Manual Isolation Valve must be fitted to the individual appliance supply line.

4. Correctly locate the appliance into its final operating position and using a spirit level, adjust the legs so that the unit is level and at the correct height.
5. Connect the gas supply to the appliance. A suitable joining compound which resists the breakdown action of LPG must be used on every gas line connection, unless compression fittings are used.
6. Check all gas connections for leakages using soapy water or other gas detecting equipment.

WARNING:

DO NOT USE A NAKED FLAME TO CHECK FOR GAS LEAKAGES.

7. Check that the gas supply pressure is as shown in the Specifications section, 'Gas Supply Requirements' tables.

NOTE:

The supply pressure to be measured at the manifold test point.

8. Light the Main Burners. Refer to the 'Operations' Section', 'Using the Griddle' / 'Using the Toaster'.
9. Verify that the supply pressure is still correct.
10. Check that the Main Burner is alight and adjust the low fire adjustment screw on the open burner gas control valves to obtain the desired flame size.
11. Check / adjust the main burner aeration gap. This gap should be set to the dimensions shown in the 'Gas Specification Tables' in 'Part 6 - Gas Conversion', 'Gas Specifications' tables.

Commissioning

The following commissioning checks must be carried out before the Gas Griddle Toaster is handed over for use, to ensure that the unit operates correctly and the operator(s) understand the correct operating procedure.

1. Before leaving the new installation;
 - a. Check the following functions in accordance with the operating instructions specified in the "Operation" section of this manual.
 - Light the Pilot Burners.
 - Light the Main Burners.
 - Check the Low Fire Burner operation.
 - Check the High Fire Burner operation.
 - b. Ensure that each operator has been instructed in the areas of correct lighting, operation, and shutdown procedures for the appliance.
2. This manual must be kept by the owner for future reference and a record of **Date of Purchase**, **Date of Installation** and **Serial Number of Unit** recorded and kept with this manual. **(These details can be found on the Rating Plate attached to the inner R/H side panel, beneath the middle shelf.**

NOTE:

If for some reason it is not possible to get the appliance to operate correctly, shut off the gas supply and contact the supplier of this unit.

Operation Guide

CAUTION:

- This appliance is for professional use and is only to be used by qualified people.
- Only Qualified service persons should be used to carry out installation, servicing or gas conversion operations.
- Components having adjustments protected (e.g. paint sealed) by the manufacturer should not be adjusted by the user / operator.

1. Cobra Gas Griddle Toasters have been designed to provide simplicity of operation and 100% safety protection.
2. Improper operation is therefore almost impossible, however bad operation practices can reduce the life of the appliance and produce a poor quality product. To use this gas griddle toaster correctly please read the following sections carefully before use.

- Lighting the Pilot Burners.
- Using the Griddle.
- Using the Toaster.

Description of Controls

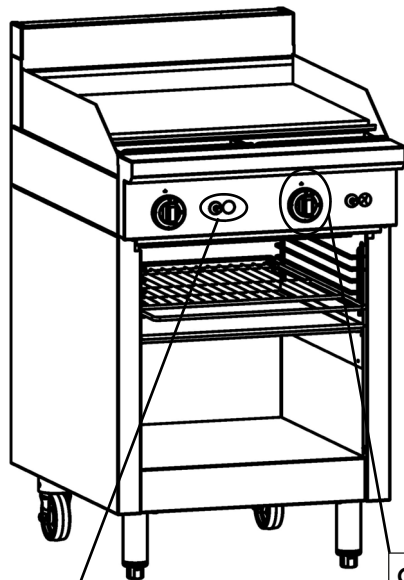

Piezo Igniter

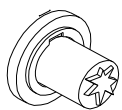

Gas Control Knob

- OFF Position.
- ☆ Pilot Burner.
- △ HIGH Flame.
- △ LOW Flame.

Lighting the Pilot Burners

1. Depress the gas control knob and rotate anti-clockwise to the 'PILOT' position.
2. Whilst holding the control knob depressed, press the piezo ignition button adjacent to the gas control knob, until the pilot burner ignites. Pilot ignition can be viewed through openings in the control panel.
3. Hold in the gas control knob for approximately 10 seconds, then release. The pilot burner should remain alight. If not repeat Items 1 to 3.
4. Repeat Items 1 to 3 to light the second pilot burner.
5. 'FULL' flame can now be achieved by rotating the gas control knob anti-clockwise to the first stop.
6. 'LOW' flame can be achieved by depressing and rotating the gas control knob fully anti-clockwise.

Using the Griddle

1. Light the pilot burners as shown above.
2. Turn the gas controls to the 'FULL' flame position. If starting from a cold start, allow the griddle plate to preheat for 10 minutes before using.
3. Place the product to be cooked onto the griddle plate.
4. For intermediate heat, position the gas control knob between the 'HIGH' and 'LOW' positions to achieve the desired heat.
5. During idle periods, the burners can be turned down to maintain an appropriate griddle plate temperature or the gas controls can be set to the 'PILOT' position as required.

Using the Toaster

1. Light the pilot burners as shown above.
2. If starting from cold, set the burners to the 'FULL' flame position and allow 5 minutes preheat before commencing toasting.
3. Adjust the rack position to the desired height.
4. Place the product on the rack to toast.
5. Best toasting results are achieved using the shaded area shown on the diagram opposite.
6. With the main burners alight, the individually controlled burners can be operated to suit food quantity requirements.
7. Each burner is operated by an 'OFF' / 'PILOT' / 'HIGH' / 'LOW' gas control. The 'HIGH' position is recommended for most grilling, cheese melting functions and the 'LOW' position for a reduced heat setting.

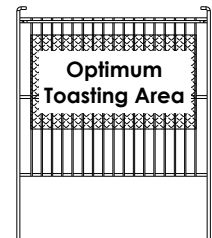

General

CAUTION:

Always turn off the gas at the main gas supply before cleaning. This appliance is not waterproof. Do not use water jet spray to clean interior or exterior of this appliance.

- To achieve the best results cleaning must be regular and thorough and all controls and mechanical parts checked and adjusted periodically by a qualified service person.
- If any small faults occur, have them attended to promptly. Don't wait until they cause a complete breakdown. It is recommended that the appliance is serviced every 6 months.
- Clean the griddle toaster regularly. A clean appliance looks better, will last longer and will perform better. Carbonised grease on the surface or on the griddle plate will hinder the transfer of heat from the cooking surface to the food. This will result in loss of cooking efficiency.

DO NOT use water on the griddle plate while this item is still hot as warping and cracking may occur. Allow the griddle plate to cool down before cleaning.

NOTE:

- **DO NOT use abrasive detergents, strong solvents or caustic detergents as they could corrode or damage the griddle toaster.**
- In order to prevent the forming of rust on the griddle plate (Steel Plate), ensure that any detergent or cleaning material has been completely removed after each cleaning. The appliance should be switched on briefly to ensure the griddle plate becomes dry. Oil or grease should be spread over the griddle surface in order to form a thin protective greasy film.

To keep your griddle toaster clean and operating at peak efficiency, follow the procedures shown opposite:-

After Each Use

CAUTION:

Always ensure that an even pressure is applied over the whole surface of the scraper tool when using on the flat surface of the griddle toaster, to prevent scoring of the surface.

NEVER bang the sharp edge of the scraper tool on the flat surface of the griddle as this will damage the finish and invalidate the warranty.

1. Clean the griddle with a scraper tool to remove any food debris.
2. Always ensure that the scraper tool blades are changed regularly to ensure that the scraper tool works efficiently and prevents damage to the griddle plate surface.

Daily Cleaning

1. The crumb tray / grease drawer should be checked and emptied frequently to prevent overflow and spillage. Remove the grease drawer while still warm so that the grease is in a liquid state. Empty any grease from the drawer and wash thoroughly in the same manner as any cooking utensil.
2. Remove the crumb tray and empty out the contents. Wash thoroughly in the same manner as any cooking utensil.
3. Thoroughly clean the splash back, interior and exterior surfaces of the range with hot water, a detergent solution and a soft scrubbing brush.
4. Brush the griddle surface with a soft bristled brush. Any carbon deposits should be removed using the supplied scraper tool followed by wiping with a cloth to prevent accumulation of food deposits.
5. Clean the control panel with a damp cloth lightly moistened with a solution of mild detergent and water. Wipe dry with a clean dry cloth.
6. Dry the griddle toaster thoroughly with a dry cloth and polish with a soft dry cloth.

Weekly Cleaning

NOTE:

- **If the griddle toaster usage is very high, we recommend that the weekly cleaning procedure is carried out on a more frequent basis.**
- **Ensure that protective gloves are worn during the cleaning process.**
- **DO NOT use harsh abrasive detergents, strong solvents or caustic detergents as they will damage the griddle toaster and burners.**
- **DO NOT use water on the griddle plate while it is still hot as warping may occur. Allow these items to cool and remove for cleaning.**

Griddle Plate

NOTE:

In order to prevent the forming of rust on the griddle plate, ensure that all detergent and cleaning material has been entirely removed after each cleaning process. The appliance should be switched on briefly to ensure the griddle plate becomes dry. Oil or grease should be spread over the griddle surface in order to form a thin protective greasy film.

- Remove and clean the grease collection drawer frequently to prevent over spills.
- Remove the crumb tray frequently to prevent overflowing the crumb tray.
- Clean the griddle surface thoroughly with a suitable scraper tool. Use a griddle stone or a scotch bright pad on the griddle surface for the removal of stubborn or accumulated carbon deposits.
- Occasionally bleach the griddle plate with vinegar when the plate is cold.
- Clean with hot water, a mild detergent solution and a scrubbing brush. Dry all components thoroughly with a dry cloth.
- The griddle plate should be switched on briefly to ensure that the griddle plate becomes dry. A thin smear of cooking oil should be spread over the griddle plate to form a protective film.

Grilling / Toasting Area

- Clean the grilling / toasting area with a soft cloth and a mild detergent and hot water solution.
- Baked on deposits or discolouration may require a good quality stainless steel cleaner or stainless steel wool. Always apply cleaner when the appliance is cold and rub in direction of grain.
- Remove the grease drawer and crumb tray, clean with a mild anti bacterial detergent and hot water solution using a soft bristled brush. Dry the grease drawer and crumb tray thoroughly with a dry cloth.

Stainless Steel Surfaces

- Clean the exterior surfaces of the griddle toaster with hot water, a mild detergent solution and a soft scrubbing brush. **Note that the gas control knobs are a push fit onto the gas control valve spindles and can be removed to allow cleaning of the front control panel.**
- Baked on deposits or discolouration may require a good quality stainless steel cleaner or stainless steel wool. Always apply cleaner when the appliance is cold and rub in the direction of the grain.
- To remove any discolouration, use an approved stainless steel cleaner or stainless steel wool. Always rub in the direction of the grain.
- Dry all components thoroughly with a dry cloth and polish with a soft dry cloth.

Periodic Maintenance

NOTE:

All maintenance operations should only be carried out by a qualified service person.

To achieve the best results cleaning must be regular and thorough and all controls and mechanical parts should be checked and adjusted periodically by a qualified service person. If any small faults occur, have them attended to promptly. Don't wait until they cause a complete breakdown. It is recommended that the appliance is serviced every 6 months.

Gas Control Valve Re-Greasing

The gas control valve should be dismantled and greased every 6 months to ensure the correct operation of the gas control valve.

To carry out this operation;-

- Remove the gas control knobs from the gas tap spindles by pulling the knobs away from the control panel.
- Remove the drip tray from the appliance.
- Remove the two screws on the underside of the control panel, securing the control panel to the hob.
- Remove the control panel from the front of the appliance.
- Remove the 2 screws holding shaft plate to gas control body and remove control shaft and plate. **Note orientation of shaft for correct re-assembly.**
- Using needle nose pliers or similar, pull out gas control spindle, again noting its orientation.
- Apply a suitable high temperature gas cock grease or lubricant such as ROCOL - A.S.P (Anti scuffing paste) / Dry Moly Paste to the outside of the spindle.
- Replace spindle and re-assemble the gas control in reverse order.
- Refit the control panel to the appliance and secure with 2 screws.
- Refit the knobs to the gas control valve spindles.

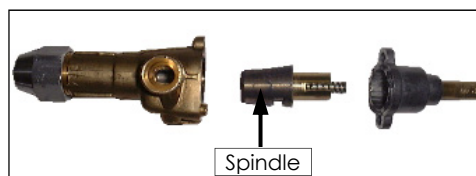
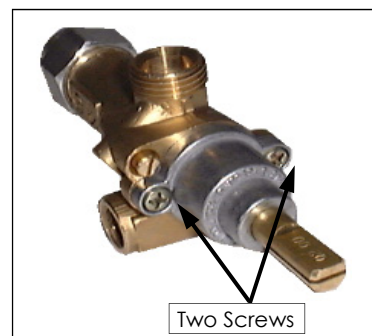

Gas Conversion Procedure

CAUTION:

Ensure that the unit is isolated from the gas supply before commencing servicing.

NOTE:

- These conversions should only be carried out by qualified service persons. All connections must be checked for leaks before re-commissioning the appliance.
- For all relevant gas specifications refer to the table at the end of this section.

Main Burners

1. Ensure that the gas supply has been turned 'Off'.
2. Remove control panel and toasting rack.
3. Unscrew the wing nut at the rear of burner and lift out the burner.

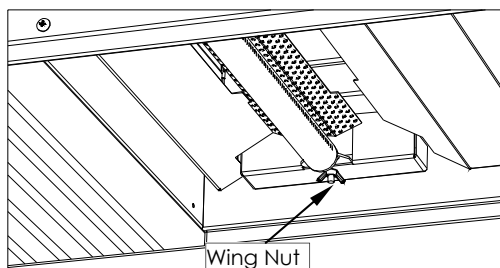

4. Determine correct injector sizes for the corresponding gas from the table shown in the 'Gas Specifications' section.
5. Remove the injectors from the injector support bracket.
6. Replace with the correct size injectors.

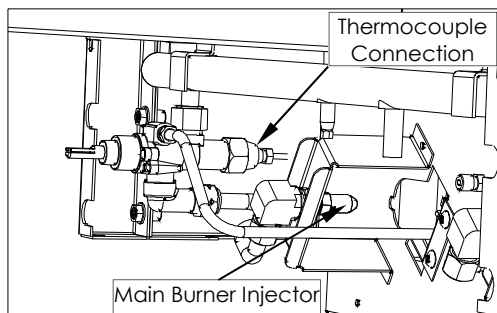

7. Repeat for the second main burner.
8. Refit the main burners to the griddle toaster.

Pilot Burners

1. Disconnect pilot supply and thermocouple tubes from the gas control valve.
2. Undo the 2 screws securing the pilot assembly to the griddle toaster main frame.

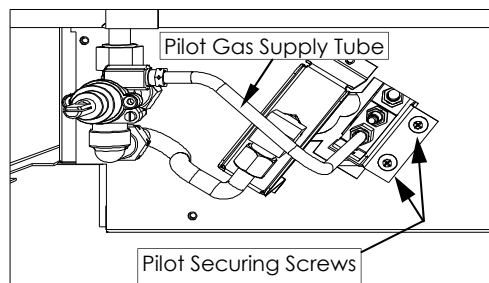

3. Withdraw the pilot assembly, remove the existing pilot injectors and replace with the correct size injectors.
4. Repeat for the second pilot burner.
5. Re-assemble the pilot burners to the griddle toaster.
6. Refit the main control panel.

Low Fire Adjustment

1. Set the burner low fire adjustment. The low fire screw on the gas control valve should be screwed fully 'In', then unscrewed by the measurement shown in the "Gas Specifications" table at the end of this section.

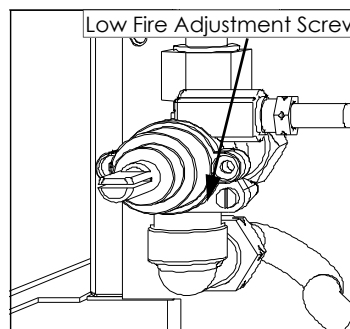

NOTE:

The "Low Fire Adjustment Screw" should be sealed with coloured paint on completion of the low fire adjustment.

2. Refit the front control panel and secure in position by tightening the 2 screws on the front lower edges of the control panel.
3. Refit the gas control knobs to the gas control valves. The gas control knobs are a push fit onto the shaft of the gas control valves.

Gas Regulator

NOTE:

The regulator supplied is convertible between Natural Gas and LPG, but its outlet pressure is fixed ex-factory and is NOT to be adjusted.

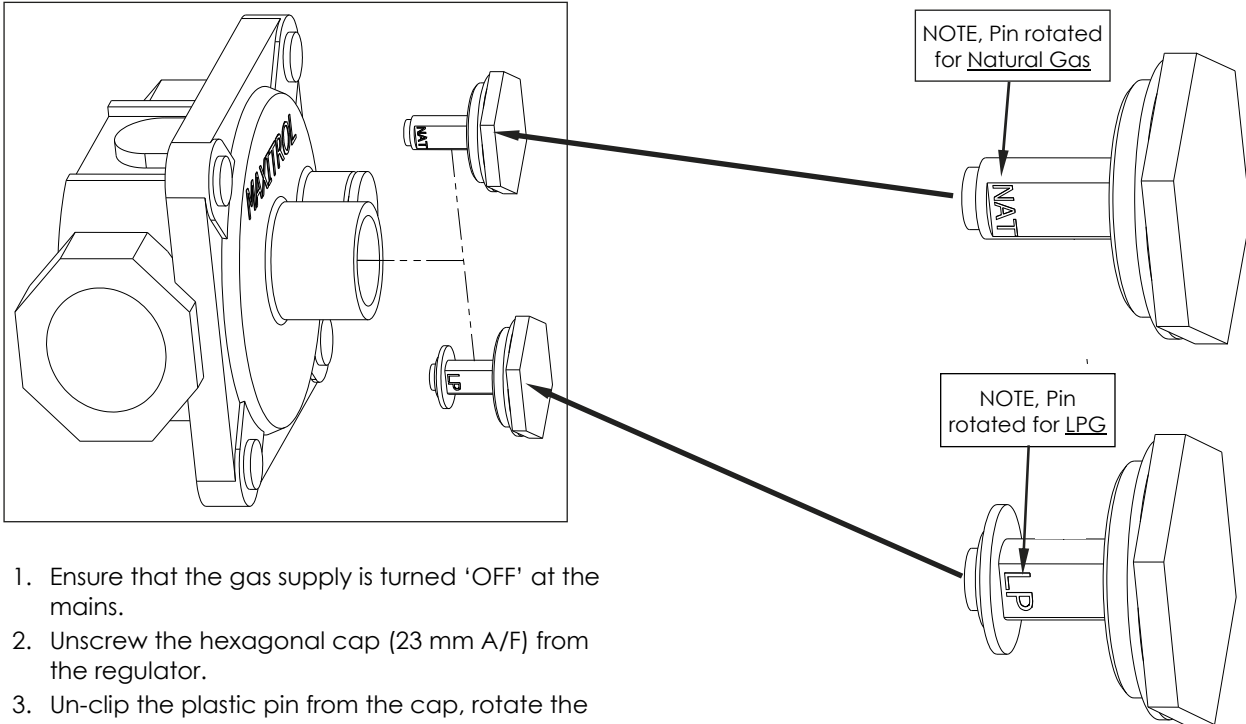

1. Ensure that the gas supply is turned 'OFF' at the mains.
2. Unscrew the hexagonal cap (23 mm A/F) from the regulator.
3. Un-clip the plastic pin from the cap, rotate the pin and re-fit it back into the cap the correct way for the gas type to be used. **(Either 'LP' or 'NAT' should be visible on the flank of the pin once re-fitted to the cap).**
4. Screw the cap back into the regulator hand tight only.

Gas Type Identification Label

On completion of the gas conversion, replace the gas type labels located at:-

- The rear of the unit, above the gas connection.
- Beside the rating plate.

Commissioning

Before leaving the converted installation;

1. Check all gas connections for leakages using soapy water or other gas detecting equipment.

WARNING:

DO NOT USE A NAKED FLAME TO CHECK FOR GAS LEAKAGES.

2. Check the following functions in accordance with the operating instructions specified in the "Operation" section of this manual.
 - Light the Main Burners.
 - Check the Low Fire Burner Operation.
 - Check the High Fire Burner Operation.
 - Ensure that all the Controls operate correctly.
 - Ensure that the Operating Pressure remains correct.

NOTE:

If for some reason it is not possible to get the appliance to operate correctly, shut off the gas supply and contact the supplier of this appliance.

Gas Specifications

- Non UK Only:

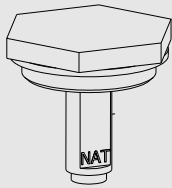
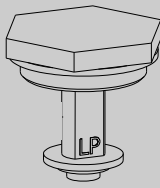
	Natural Gas	LP Gas (Propane)
Main Burner Injectors	Ø 2.10 mm	Ø 1.30 mm
Pilot Burner Injectors	0.35	0.23
Low Fire Adjustment	1 turn out (ccw)	½ turn out (ccw)
Operating Pressure	1.0 kPa (*)	2.5 kPa (*)
Main Burner Aeration Shutter	Fully Open	Fully Open
Gas Regulator Cap Screw		

- UK Only:

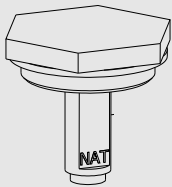
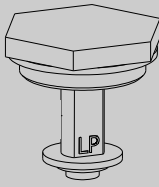
	Natural Gas (G20)	Propane (G31)
Main Burner Injectors	Ø 2.10 mm	Ø 1.30 mm
Pilot Burner Injectors	0.35	0.23
Low Fire Adjustment	1½ turns out (ccw)	½ turn out (ccw)
Operating Pressure	10 mbar (*)	26 mbar (*)
Main Burner Aeration Shutter	Fully Open	Fully Open
Gas Regulator Cap Screw		

NOTE:

- * The burner operating pressure is to be measured at the manifold test point with both burners operating at full setting. The operating pressure is ex-factory set, through the appliance regulator and is not to be adjusted, apart from when carrying out gas conversion. (Refer to the 'Gas Conversion' information for details).

Replacement Parts List

IMPORTANT:

Only genuine qualified replacement parts should be used for the servicing and repair of this appliance. The instructions supplied with the parts should be followed when replacing components.

For further information and servicing instructions, contact your nearest qualified service branch (contact details are as shown on the reverse of the front cover of this manual).

When ordering spare parts, please quote the part number and the description as listed below. If the part required is not listed below, request the part by description and quote model number and serial number which is shown on the rating plate.

Controls

231558	Burner - Griddle Toaster.		
037210	Burner Injector	(Natural Gas)	Ø 2.10 mm.
037130	Burner Injector	(LPG)	Ø 1.30 mm.
227403	Gas Control Valve.		
019215K	Pilot Burner.		
026488	Pilot Injector	(Natural Gas)	0.35.
019217	Pilot Injector	(LPG)	0.23.
019428	Thermocouple.		
230608	Gas Control Knob.		
230586	Piezo Igniter.		
228533	Regulator (RV47) -	(Natural Gas/LPG - convertible) - 1/2" BSP F/F.	
228047	HT Lead 250 mm.		

General

227007	Toasting Rack.
227006	Side Racks.
229987	Crumb Tray (Enamelled).
230289	Grease Tray.
230578	Adjustable Legs (150 mm).
229674	Rear Roller Assy.

Gas Conversion Kits

Model	Gas Type to Convert to:	
	Nat. Gas (G20)	Propane (G31)
CT6	231553	231554

