



# DISHWASHER X-50BD 230/50/1 DD (BUILT-IN WATER SOFTENER AND DRAIN PUMP)

Multi-phase dishwasher. 500x500mm. racks. Max. loading height: 330mm.

P/N 1302114



## FEATURES AND BENEFITS

X-50 dishwasher is equipped with a high quality electronic panel complete with **wash and rinse temperature display**. Easy to use, X-50 is a **multi-phase dishwasher**:

- ✓ **230V / 50Hz / 1~ (standard)**
- ✓ **400V / 50Hz / 3N~**
- ✓ **230V / 50Hz / 3~**
- ✓ For washing glasses, cups, cutlery and small plates.
- ✓ Washing with double system of rotating dispersers (top and bottom).
- ✓ 3 wash cycles.
- ✓ Manufactured from catering grade AISI 304 2B stainless steel and incorporating top quality components.
- ✓ Double skinned door with high efficiency seal, ensuring thermal and acoustic insulation. Magnetic door micro-switch.
- ✓ Easy to use electronic control panel with anti-moisture seal and wash & rinse tank temperature displays.
- ✓ Removable stainless steel rack holders ensure even distribution of wash water without dead zones. Precision positioned water jets guarantee optimum washing result for even the most stubbornly stained glasses. Easy to assemble, boltless rinse spray arms.
- ✓ A double filter system provides effective wash pump protection that is easily removed (for maintenance and cleaning) and replaced, without tools.
- ✓ Inside of the machine with rounded finished: absence of angles avoiding the accumulation of dirt.
- ✓ Completely rounded, stainless steel wire rack support and guide.
- ✓ Automatic detergent and rinse aid dosing equipment.
- ✓ Adjustable washing tank and boiler temperature and security in the boiler.
- ✓ Rinse boiler temperature adjustment and a thermal cycle delay option, guaranteeing a minimum final rinse temperature of 85°C for each and every rinse cycle.
- ✓ The dual voltage option facilitates connection to single or 3 phase supply within the same appliance.
- ✓ Sammic ware washers are designed for easy and fast on-site maintenance.
- ✓ 100% tested.

## SALES DESCRIPTION

Commercial multi-phase, multi-power dishwasher with 3 wash cycles, wash and rinse temperature display and thermal cycle delay option.

- ✓ Best performance.
- ✓ Optimal washing results.
- ✓ Sturdy and reliable.
- ✓ Stainless steel, sturdy and resistant washing arms. Don't get damaged because of chemical corrosion.
- ✓ Full optional list.

## INCLUDES

- ✓ Rinse aid doser.
- ✓ Variable detergent dosing equipment.
- ✓ Drain pump and non-return valve available.
- ✓ Built-in water softener.
- ✓ 1 open basket.
- ✓ 1 mixed basket.
- ✓ 1 small cutlery basket.



[www.sammic.co.uk](http://www.sammic.co.uk)

Food Service Equipment Manufacturer

Unit 2, Trevanah Road  
Troon Industrial Park  
LE4 9LS - Leicester

[uksales@sammic.com](mailto:uksales@sammic.com)  
Tel.: +44 0116 246 1900



Project	Date
Item	Qty
Approved	



# DISHWASHER X-50BD 230/50/1 DD (BUILT-IN WATER SOFTENER AND DRAIN PUMP)

Multi-phase dishwasher. 500x500mm. racks. Max. loading height: 330mm.



P/N 1302114

## SPECIFICATIONS

Basket dimensions: 500 mm x 500 mm

Maximum glass height: 330 mm

Cycle duration: 120 " / 150 " / 210 "

Production baskets/hour: 30 / 24 / 17

Wash temperature: 0 °C - 65 °C

Rinse temperature: 0 °C - 90 °C

✓ Boiler capacity: 10 l

✓ Wash tank capacity: 26 l

✓ Water consumption/cycle: 2.9 l

✓

### Electrical supply: multiphase

✓ 230 V / 50 Hz / 1 ~ (15.5/22 A)

✓ 230 V / 50 Hz / 3 ~ (12.8 A)

✓ 400 V / 50 Hz / 3N ~ (7.6 A)

✓

### Plug: -

### Loading

✓ Pump: 370 W / 0.5 Hp

✓ Tank: 2500 W

✓ Boiler: 3000/4500 W

✓ Total loading: 3370/4870 W

✓

### External dimensions (WxDxH)

✓ Width: 600 mm

✓ Depth: 630 mm

✓ Height: 835 mm

Net weight: 66,3 Kg

### Crated dimensions

640 x 695 x 960 mm

Gross weight: 72.7 Kg.

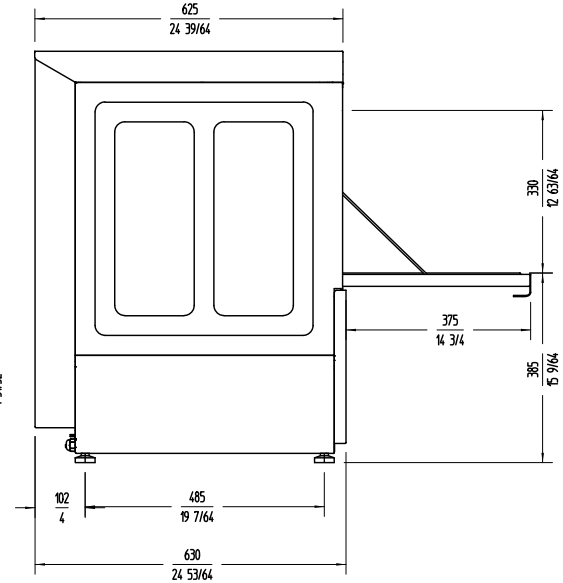
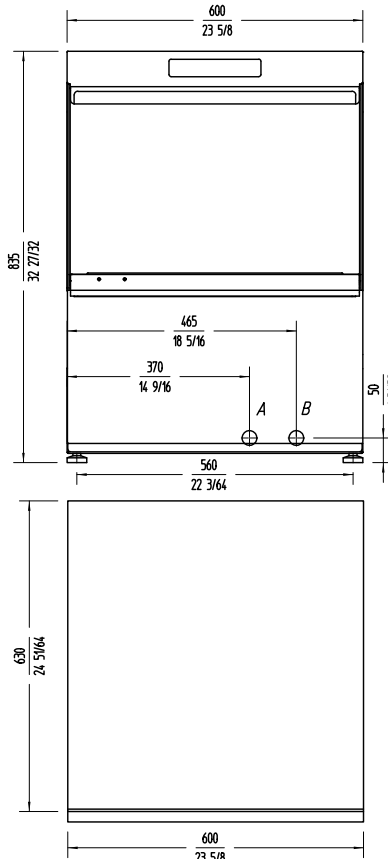

WARE WASHING  
COMMERCIAL DISHWASHERS



[www.sammic.co.uk](http://www.sammic.co.uk)

Food Service Equipment Manufacturer

Unit 2, Trevanah Road

Troon Industrial Park

LE4 9LS - Leicester

[uksales@sammic.com](mailto:uksales@sammic.com)

Tel.: +44 0116 246 1900



Project

Date

Item

Qty

Approved

product sheet  
updated 07/05/2018