



## P8P5PT - Panther 800 Series Free-standing Hot Cupboard - Plain Top - W 1855 mm - 2.5 kW

Helping to cater in demanding environments such as cafeterias, canteens and restaurants, the Panther 800 Series Hot Cupboard is perfect for plating and garnishing and as a pass to front of house staff, while it also provides extra workspace or can be used as a mobile workstation.

- ✓ Helping to cater in demanding environments such as cafeterias, canteens and restaurants
- ✓ Accurate digital electronic control of the hot cupboard temperature, adjustable between 20 and 99 °C, ensures compliance with food hygiene regulations
- ✓ Pass through model with removable sliding doors to both sides provide enhanced workflow efficiency
- ✓ Double skinned construction provides efficient heat retention and a cool to touch exterior - safe and energy efficient. Removable doors and shelves allow access to the fully stainless steel interior for easy cleaning
- ✓ Fan assisted hot cupboard provides even heat distribution, fast heat up and recovery times, and lower energy usage. Four shelf positions allow adjustment to meet individual needs.
- ✓ Fully 1/1 GN compatible hot cupboard for operational efficiency. Units available to take 5 x 1/1 GN containers up to 150mm deep.
- ✓ Supplied with two heavy duty multi-section chrome plated rod shelves capable of taking the heaviest loads

### Specifications

Summary		Power and Performance	
Range Name	Panther	Total Power kW	2.5
Power Type	Electric	Temperature Range °C	20 - 99
Unit Type	Free-standing	IP Rating	IP24
Available in UK Only	No	Plate Capacity	476
UK Warranty	2 Years Parts and Labour Warranty	Temperature Control	Electronic
Export Warranty	Contact your local dealer		
GTIN Code	5056105103608		

Key Specifications		Weights and Dimensions	
Number of Shelves included	2	Unit Height (External) mm	900
Number of Shelf Positions	4	Unit Width (External) mm	1855
Heated Base	Yes	Unit Depth (External) mm	850
Heated Gantry	No	Height (Internal) mm	432
Static or Mobile	Mobile	Width (Internal) mm	1670
		Depth (Internal) mm	512
		Shelf Dimensions Width mm	1610
		Shelf Dimensions Depth mm	512
		Net Weight Kg	171

Supply Connections		Shipping	
Requires Installation	No	Packed Weight Kg	201
Requires Electrical Supply	Yes	Packed Height cm	110
UK 3 Pin Plug	Yes	Packed Width cm	188
Requires Hardwiring	No	Packed Depth cm	90
Electrical Supply Rating Watts	2,500		
Single Phase Amps	10.9		
Single Phase Voltage	230		

**Available Options**

**Overshelf or Gantry**

<b>PG5A</b>	PG5A - Ambient Gantry
<b>PG5H</b>	PG5H - Heated Gantry
<b>PS5A1</b>	PS5A1 - 1 Ambient Overshelf
<b>PS5A2</b>	PS5A2 - 2 Ambient Overshelves
<b>PS5A3</b>	PS5A3 - 3 Ambient Overshelves
<b>PS5H1</b>	PS5H1 - 1 Heated Overshelf
<b>PS5H2</b>	PS5H2 - 2 Heated Overshelves
<b>PS5H3</b>	PS5H3 - 3 Heated Overshelves

**Door Locks**

<b>PDL5</b>	PDL5 - Lockable Door
-------------	----------------------

**Corner Guards**

<b>PCG</b>	PCG - Corner Guards [Set of Four]
------------	-----------------------------------

**Legs/Castors**

<b>PLK</b>	PLK - Legs [non chargeable]
------------	-----------------------------

**Available Accessories**

<b>PLK/S</b>	PANTHER LEG KIT FOR CONVERSION IN THE FIELD
--------------	---

**Technical Picture**

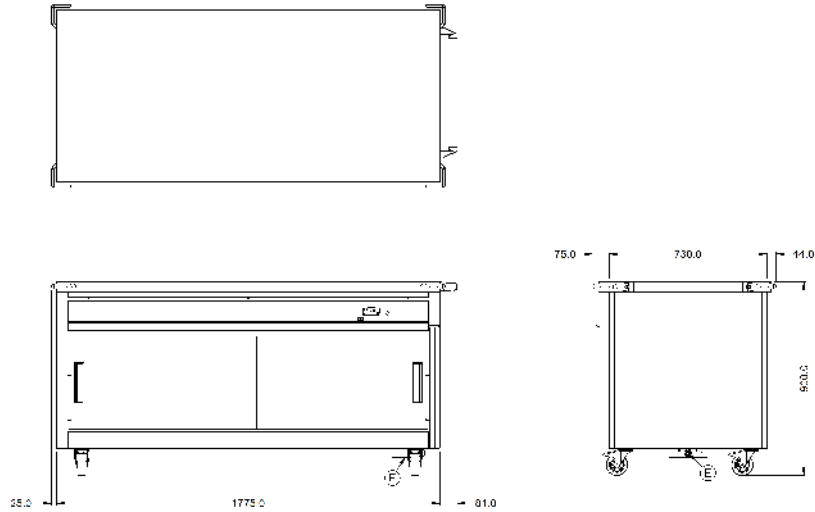

**Lincat Limited**

Whisby Road,  
Lincoln, LN6 3QZ,  
United Kingdom

**Company No:** 2175448

A member company of



**Customer Care**

**Tel:** +44 1522 875500  
**Email:** care@lincat.co.uk

**Export Customers**

**Tel:** +44 1522 503250  
**Email:** export@lincat.co.uk

**Opening Hours**

**Monday – Friday:**  
8.30am – 5pm