



P8B4PT - Panther 800 Series Free-standing Hot Cupboard - Bain Marie Top - 4GN - W 1530 mm - 4.9 kW

Helping to cater in demanding environments such as cafeterias, canteens and restaurants, the Panther 800 Series Hot Cupboard / Bain Marie is an effective way of holding food at the desired temperature, and is perfect for holding carvery and breakfast items either for self service or for back service.

- ✔ Helping to cater in demanding environments such as cafeterias, canteens and restaurants
- ✔ Pass through model with removable sliding doors to both sides provide enhanced workflow efficiency
- ✔ Fan assisted hot cupboard provides even heat distribution, fast heat up and recovery times, and lower energy usage. Four shelf positions allow adjustment to meet individual needs.
- ✔ Fully 1/1 GN compatible hot cupboard for operational efficiency. Units available to take 4 x 1/1 GN containers up to 150mm deep.
- ✔ Thermostatically controlled bain marie top can be operated with wet or dry heat. Accurate digital electronic control of the hot cupboard temperature, adjustable between 20 and 99 °C, ensures compliance with food hygiene regulations
- ✔ Double skinned construction provides efficient heat retention and a cool to touch exterior - safe and energy efficient. Removable doors and shelves allow access to the fully stainless steel interior for easy cleaning
- ✔ Supplied with two heavy duty multi-section chrome plated rod shelves capable of taking the heaviest loads
- ✔ Drain tap located inside the hot cupboard allows fast and easy draining

Specifications

Summary		Power and Performance	
Range Name	Panther	Gastronorm Capacity	4 x GN1/1
Power Type	Electric	Total Power kW	4.9
Unit Type	Free-standing	Temperature Range °C	20 - 99
Available in UK Only	No	IP Rating	IP24
UK Warranty	2 Years Parts and Labour Warranty	Plate Capacity	396
Export Warranty	Contact your local dealer	Temperature Control	Top: Mechanical/Bottom: Electronic
GTIN Code	5056105103509		

Key Specifications

Key Specifications		Weights and Dimensions	
Drain Location	Right side interior mounted	Unit Height (External) mm	912
Number of Shelves included	2	Unit Width (External) mm	1530
Number of Shelf Positions	4	Unit Depth (External) mm	850
Pot Type	Gastronorm	Height (Internal) mm	432
Type of Heat	Wet/Dry	Width (Internal) mm	1345
Heated Base	Yes	Depth (Internal) mm	512
Heated Gantry	No	Shelf Dimensions Width mm	1286
Static or Mobile	Mobile	Shelf Dimensions Depth mm	512
		Net Weight Kg	120

Supply Connections

Requires Installation	Yes
Requires Electrical Supply	Yes
UK 3 Pin Plug	No
Requires Hardwiring	Yes
Electrical Supply Rating Watts	4,900
Single Phase Amps	21.5
Single Phase Voltage	230

Shipping

Packed Weight Kg	135
Packed Height cm	110
Packed Width cm	155
Packed Depth cm	90

Available Options

Overshelf or Gantry

PG4A	PG4A - Ambient Gantry
PG4H	PG4H - Heated Gantry
PS3H3	PS3H3 - 3 Heated Overshelves
PS4A1	PS4A1 - 1 Ambient Overshelf
PS4A2	PS4A2 - 2 Ambient Overshelves
PS4A3	PS4A3 - 3 Ambient Overshelves
PS4H1	PS4H1 - 1 Heated Overshelf
PS4H2	PS4H2 - 2 Heated Overshelves

Door Locks

PDL4	PDL4 - Lockable Door
------	----------------------

Corner Guards

PCG	PCG - Corner Guards [Set of Four]
-----	-----------------------------------

Legs/Castors

PLK	PLK - Legs [non chargeable]
-----	-----------------------------

Available Accessories

CP16	CARVERY PAD 1/1 GAST
PGK1	GN PACK 1
PGK10	1 x PGK1 + 1 x PGK3
PGK11	1 x PGK2 + 1 x PGK3
PGK12	2 x PGK3
PGK2	GN PACK 2
PGK3	GN PACK 3
PGK8	2 x PGK1
PGK9	1 x PGK1 + 1 x PGK2
PHTC	PANTHER - CERAMIC INSERT - 1/1 GN SIZE CERAMIC INSERT
PHTG	PANTHER - GLASS INSERT - 1/1 GN SIZE GLASS INSERT
PLK/S	PANTHER LEG KIT FOR CONVERSION IN THE FIELD

Technical Picture

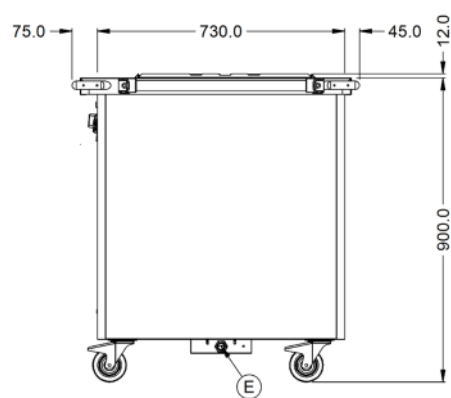
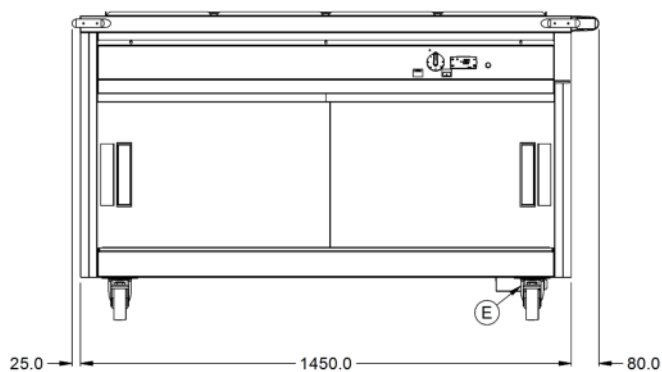
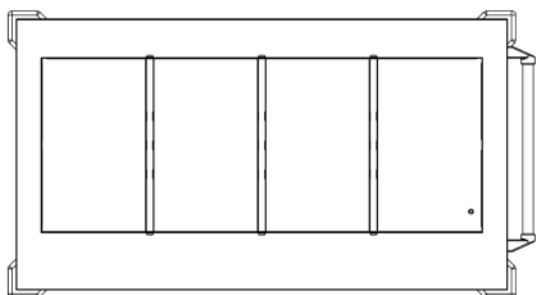

Lincat Limited

Whisby Road,
Lincoln, LN6 3QZ,
United Kingdom

Company No: 2175448

A member company of



Customer Care

Tel: +44 1522 875500
Email: care@lincat.co.uk

Export Customers

Tel: +44 1522 503250
Email: export@lincat.co.uk

Opening Hours

Monday – Friday:
8.30am – 5pm