



Electrolux

Vegetable Slicer TRK45 Cutter Slicer - 4.5 LT - Variable Speed - UK Plug

ITEM # _____

MODEL # _____

NAME # _____

SIS # _____

AIA # _____



Vegetable Slicer

TRK45 Cutter Slicer - 4.5 LT - Variable Speed -
UK Plug

603702 (TRK45VVEG)

Combined cutter/vegetable slicer, variable speed 300 to 3700 rpm. Supplied with 4,5 lt stainless steel cutter bowl and lever operated feed hopper (UK)

and waterproof control panel with on/off button, pulse function and variable speed (from 300 to 3700 rpm). UK plug.

Short Form Specification

Item No.

3 in 1 machine: cutter, emulsifier and slicer to slice, grate, liquidise, mix and mince in a matter of seconds. Easily change from vegetable slicer to food processor without any tool. All parts in contact with food are removable, dismantable and dw safe. Incl system to change the motor base orientation (20°) to facilitate loading and unloading operations with the vegetable slicer attachment. Vegetable slicer attachment: Universal vegetable slicer offering more than 80 different types of cuts. Long vegetable hopper (60mm diameter) integrated in the wide 3/4 moon stainless steel round hopper (215cm²). User-friendly stainless steel lever (better pressure control, with less effort for arms and shoulder), designed for right and left handed users. High discharge zone (up to 20cm) for GN containers. Automatic start/stop function will stop the machine when the lever hopper is lifted and will restart automatically when lowered.

Cutter-mixer: Stainless steel 4,5 litre bowl with unique design for mixing both large or small quantities. Unique high chimney increases the real capacity of the bowl (use up to 75% of nominal capacity). Transparent lid to check consistency of food and to eventually add ingredients without having to open the lid. Hinged cover, when lifted, remains open to permit a fast and easy check of preparation. Ergonomic and easily dismantable scraper, in heavy duty composite material, for better homogenization. Micro toothed blades in 420 AISI stainless steel. Multiple safety devices ensure the machine will only operate when the cover is properly closed and all parts are correctly positioned. Asynchronous industrial motor for heavy duty and longer life. Flat

APPROVAL: _____



Electrolux

TRK45 Cutter Slicer - 4.5 LT - Variable Speed - UK Plug
Vegetable Slicer

Main Features

- 3 in 1 machine: cutter, emulsifier and vegetable slicer to slice, grate, liquidise, mix and mince in a matter of seconds.
- Incl system to incline motor base at 20° to better fit the vegetable slicer attachment.
- Delivered with:
 - Stainless steel lever operated feed hopper.
 - 4,5 lt stainless steel cutter bowl, transparent lid, scraper and microtoothed blade rotor.
- Vegetable slicer unit has slicing, grating, shredding (julienne) as well as dicing and french fries capabilities.
- Long vegetables round hopper integrated in the feed arm, 3/4 moon roundish hopper to limit pre cutting operations.
- Emulsifier function (scraper) included as standard.
- Base fixed cover for a better handling.
- Red OFF, green ON buttons.
- Pulse function to coarse chopping.
- All parts in contact with food are removable without the use of tools, completely dismantlable and dishwasher safe.
- Automatic restart of the machine with the 3/4 moon shaped pusher in position.
- Magnetic safety system and motor brake. Prevents machine from running when vegetable preparation lever and/or hopper are lifted or when cutter lid is not properly closed.
- Automatic speed limitation according to the selected function (slicer or cutter).
- Complete and wide selection of blades and grids available (diam. 205 mm)
- Capacity:
 - vegetable slicer productivity 550 kg/h, suitable for 100-400 meals for table service, up to 800 meals for catering service.
 - cutter mixer working capacity from 100 g to 2 kg, for 50-80 meals per service.

Construction

- Asynchronous industrial motor with no brushes for high reliability and quiet functioning, stainless steel motor shaft.
- Stainless steel bowl has a high chimney to ensure high productivity also when processing liquids (75% of the nominal capacity).
- Feeding arm and hopper are made entirely in stainless steel. Aluminum motor housing.
- Vegetable cutting at 4 speeds up to 800 rpm. Food processing at 10 variable speeds: 300-3700 rpm.
- Power: TRK45 - 1.3 HP.
- IPX5 (IP55) flat panel touch-control, waterproof panel.
- Compact and portable design.
- All blades (available on request) are made in stainless steel and dishwasher safe.
- Water protected planetary system (IP55 electrical controls, IP23 overall machine).

Included Accessories

- 1 of Microtoothed blade rotor for 4,5 lt cutter mixer PNC 653580
- 1 of Lid and bowl scraper for 4,5 lt cutter mixer PNC 653588
- 1 of Stainless steel bowl, 4,5 lt capacity PNC 653589
- 1 of Ejector disc PNC 653772

Optional Accessories

- Microtooth blade rotor (emulsifier) for 4,5 lt cutter mixer PNC 650039
- Stainless steel pressing/slicing disc with S-blades (balanced) 5 mm (can be used for slicing or combined with grids) PNC 650048
- Stainless steel pressing/slicing disc with S-blades (balanced) 6 mm (can be used for slicing or combined with grids) PNC 650049
- Stainless steel pressing/slicing disc with S-blades (balanced) 8 mm (can be used for slicing or combined with grids) PNC 650050
- Stainless steel pressing/slicing disc with S-blades (balanced) 10 mm (can be used for slicing or combined with grids) PNC 650051
- Stainless steel pressing/slicing disc with S-blades (balanced) 10 mm (can be used for slicing or combined with grids) PNC 650052
- Stainless steel pressing/slicing disc with S-blades (balanced) 12 mm (can be used for slicing or combined with grids) PNC 650053
- Stainless steel pressing/slicing disc with S-blades (balanced) 13 mm (can be used for slicing or combined with grids) PNC 650054
- Stainless steel pressing/slicing disc with corrugated S-blades (balanced) 8 mm (can be used for slicing or combined with grids) PNC 650055
- Stainless steel pressing/slicing disc with corrugated S-blades (balanced) 10 mm (can be used for slicing or combined with grids) PNC 650056
- Stainless steel work table with folding shelves and disk rack PNC 653283
- Dicing grid 5x5 mm PNC 653566
- Dicing grid 8x8 mm PNC 653567
- Dicing grid 10x10 mm PNC 653568
- Dicing grid 12x12 mm PNC 653569
- Dicing grid 20x20 mm PNC 653570
- Grid for chips 6x6 mm PNC 653571
- Grid for chips 8x8 mm PNC 653572
- Grid for chips 10x10 mm PNC 653573
- Smooth blade rotor for 4,5 lt cutter mixer PNC 653579
- Microtoothed blade rotor for 4,5 lt cutter mixer PNC 653580
- Lid and bowl scraper for 4,5 lt cutter mixer PNC 653588
- Stainless steel bowl, 4,5 lt capacity PNC 653589

- Kit to convert variable speed food processor into vegetable slicer (incl. stainless steel hopper, manual lever, cutting chamber, ejector and adjustable base) PNC 653594
- Smooth blade rotor (emulsifier) for 4,5 lt cutter mixer PNC 653614
- Stainless steel slicing disc with S-blades 0,6 mm PNC 653728
- Stainless steel slicing disc with S-blades 1 mm PNC 653729
- Stainless steel slicing disc with S-blades 2 mm PNC 653730
- Stainless steel slicing disc with S-blades 3 mm PNC 653731
- Stainless steel slicing disc with S-blades 4 mm PNC 653732
- Stainless steel slicing disc with S-blades 5 mm PNC 653733
- Stainless steel slicing disc with S-blades 6 mm PNC 653735
- Stainless steel slicing disc with S-blades 8 mm PNC 653737
- Stainless steel shredding disc with S-blades 2x2 mm PNC 653743
- Stainless steel shredding disc with S-blades 3x3 mm PNC 653744
- Stainless steel shredding disc with S-blades 4x4 mm PNC 653745
- Stainless steel shredding disc with S-blades 6x6 mm (can also be used for chips) PNC 653746
- Stainless steel shredding disc with S-blades 8x8 mm (can also be used for chips) PNC 653747
- Stainless steel shredding disc with S-blades 10x10 mm (can also be used for chips) PNC 653748
- Stainless steel disc with corrugated S-blades 2 mm PNC 653749
- Stainless steel disc with corrugated S-blades 3 mm PNC 653750
- Stainless steel disc with corrugated S-blades 6 mm PNC 653751
- Ejector disc PNC 653772
- Stainless steel grating disc 2 mm PNC 653773
- Stainless steel grating disc 3 mm PNC 653774
- Stainless steel grating disc 4 mm PNC 653775
- Stainless steel grating disc 7 mm PNC 653776
- Stainless steel grating disc 9 mm PNC 653777
- Stainless steel grating disc for knoedeln and bread PNC 653778
- Stainless steel grating disc for parmesan and bread PNC 653779
- Bistrot Pack-set stainless steel discs (C2S-2mm slicing disc, C5S-5mm slicing disc, J2X-2mm grating disc) PNC 653785
- Gastronomy Pack-set stainless steel discs (C2S-2mm slicing disc, C5S-5mm slicing disc, J2X-2mm grating disc, AS4X-4x4mm shredding disc, C10PS-10mm presser/slicer, MT10T-10x10mm dicing grid) PNC 653786

Front

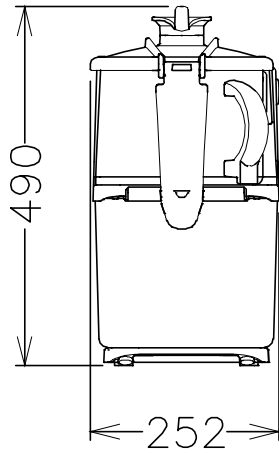

Top

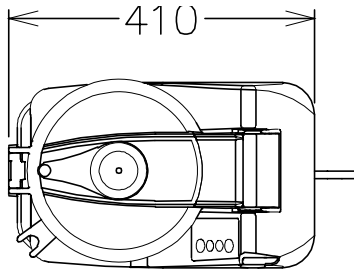

Side

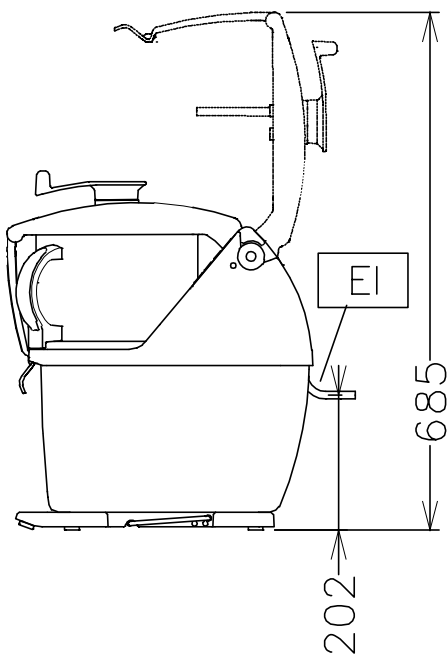

EI = Electrical connection
EQ = Equipotential screw

Electric

Supply voltage:	
603702 (TRK45VVEG)	200...240 V/1N ph/50/60 Hz
Electrical power:	1 kW
Total Watts:	1 kW

Capacity

Performance (up to):	550 - kg/hour
Capacity	4.5 liter

Key Information

External dimensions, Height	505 mm
External dimensions, Width	252 mm
External dimensions, Depth	485 mm
Shipping weight:	30.5 kg