



CAS

Electric Sandwich/Pizza Grill



British Built for Purpose.





Welcome to Parry

Parry is one of the UK's foremost manufacturers of high-quality Stainless Steel Fabricated Products with a 40-year heritage rooted in British craftsmanship.

At Parry, quality and service are second nature. Striving to exceed our customers' expectations is not just our motto; it's the very heartbeat of our business. Our commitment to our customers is reflected in the **Parry 4E Standard Inspection Body** stating that all our products are:



Easy to use



Easy to maintain



Easy to clean



Easy to repair

Our ranges of Stainless Steel Products have been specifically designed with the consumer in mind and are tailored and compliant to your specific industry sector. All our products are 4E Compliant and meet EU & UK regulations, where applicable. The Parry brand stands for quality, reliability and value.

Our British designed products have been created by our expert in-house development team and manufactured to exacting standards using Industry specified grade of European stainless steel and holding relevant EU & UK certification for all product.

ISO9001 certification and continual investment in the training and development of our highly skilled, artisan workforce means that our clients have genuine peace of mind that they are buying hand crafted, quality products supported by five-star customer service. All Parry products meet EU regulations for their respective sector.

We are LEAN manufacturers, minimising waste, maximising productivity. We are proud to run an operation that is committed to minimising our impact on the environment.

Our equipment and furniture are manufactured in our 45,000 sq ft manufacturing facility in Draycott, Derbyshire in England's industrial heartland. Products are made to order if not available in our stocked items which means you can choose from 600 products, offering over 3,500 variants, with short lead times to suit your specific needs. That means you get exactly what you need when you need it.

Our product information can be found here, in our brochure or on our website www.parry.co.uk.

You have my personal commitment that Parry will exceed your expectations. Should you have any questions please contact your distributor. Alternatively, our customer services team will be happy to help you on **01332 875544**.

Mark Banton MBA
Managing Director



Contents

Contents.....	1
Product Overview	2-3
Safety Instructions	4
Installation Instructions	4
Operating Instructions	5
Cleaning Instructions	6
Maintenance Instructions.....	6
Fault Finding	7
Service Information.....	8
Wiring Diagram	9
Exploded View	10
Parts List	11
Warranty Information.....	12
Disposal & Recycling	13

Parry Catering Equipment (Midlands) Ltd, Town End Road, Draycott, Derby, DE72 3PT.
Sales Tel: 01332 875544







Product Overview

CAS – ELECTRIC SANDWICH GRILL

The Parry CAS is an electric sandwich grill with reliable instant heat, infrared elements and automatic timer. The simple dial controls ensure that the independently operated quartz elements are easy to use and the stainless steel construction and removable crumb tray assists with easy cleaning. Powerful and versatile, the sandwich toaster can be positioned on a countertop or wall mounted, so it would fit well in most commercial restaurant kitchens.

These Units lead the industry in:

-  Design and aesthetic appeal
-  Performance
-  Power
-  Functionality
-  After sales support





Product Overview

Features	CAS
Unpacked weight (kg)	15
Packed Weight (kg)	18
Dimensions (w x d x h) mm	520 x 420 x 315
Internal Dimensions (w x d x h) mm	440 x 230 x 50
Plate dimensions (w x d) mm	n/a
Element Type	Infra-red
Plug	Yes
Power rating	3kW
Warranty	2 years



Safety Instructions

IMPORTANT



Please read these instructions before you attempt to use the equipment. Keep these instructions for future reference.

WARNING

To avoid scratching the highly polished exterior surface of this equipment whilst in transit, the protective film on the exterior surfaces has NOT been removed.



It is IMPORTANT that this protective film is peeled off before the equipment is used.

WARNING

-  All electrical appliances/parts must be earthed.
-  No user-serviceable parts.
-  Isolate power supply before carrying out any installation work.





Installation Instructions

-  Choose a suitable site for your machine taking into consideration its, use and any heat that may be generated whilst in service.
-  Remove all protective film and packaging materials and inspect for any damage which may affect the machines electrical safety.
-  All appliances with an electrical loading above 3 kilowatts must be connected to a suitable supply by a qualified electrician, who should ensure that:
 - a) Precaution is taken during installation regarding leakage current.
 - b) The means of isolation has a contact separation of at least 3mm on all poles.
 - c) The machine is installed in accordance with Health and Safety at Work Act, BS Codes of Practice, IEE Wiring Regulations and Building and Local Authority Standards.



Operating Instructions

The 15-minute timer is an overall on/off switch to all bars. It emits an audible click when operating and automatically switches off all bars when the pre-set time has elapsed. To ensure that the timer is working correctly, first turn the timer to the full position, then return to the required setting. It has a “hold” position for continuous heating.

-  Switch on power supply, the red lamp will indicate the power is ON.
-  Turn the temperature dial to the required setting (1-2½ the top tubes will turn ON and OFF to regulate the heat. The lower the setting the elements turn on less frequent. Number 3 is for maximum continuous heat).

N.B..

- a) All tubes are operated by two ON/OFF switches, on CPG models.
- b) The top tubes are controlled by a simmer stat and bottom tubes by an ON/OFF switch on CAS models.

Cooking Options

Sandwiches should always be toasted in the special INFRA-RED bags, and meat fillings always pre-cooked.





Suggested fillings:

Cheese and Tomato
Cheese and boiled ham
Cheese and Onions
Cheese and Sweet Pickle
Cheese and Luncheon Meat
Ham and Pineapple
Cooked Bacon and Tomato
Tongue and Sweet Pickle
Hamburger and Onions
Luncheon Meat and Onions
Luncheon Meat, Cheese and Onions
Turkey and Chicken
Various Cooked Meats
Corned Beef and Onions



Cleaning Instructions

The appliance should be cleaned after every use.

-  Allow unit to cool down before cleaning
-  Turn off unit at the mains power.
-  Wipe down the machine with a soft cloth, do not use abrasive materials.
-  Stainless steel cleaners maybe used and cleaning instructions on the product must be adhered to.
-  Never clean the unit with water jets.



Maintenance Instructions

Ensure the appliance is isolated from the power supply before installing, cleaning or maintaining the appliance.

Maintenance and service must only be undertaken by a qualified electrician.

SPARE
PARTS



Parry Catering provides a complete after-sales service by offering the sales of spare parts directly to customers. Buying spares straight from the manufacturer allows customer to experience exceptional value and speedy delivery on all spare parts.

For more information on buying spares visit:

www.parry.co.uk/parry-commercial-catering-spares



Fault Finding

Fault	Check	Solution
Unit not working	Check that the power switch is illuminated. If there is no illumination	Turn on mains power
	Check Socket	Plug unit into another socket.
	Check fuse in plug	Replace fuse in plug.
		Contact engineer if all of the above has been checked.
Heating elements not functioning	Check that the timer is turned to the on position	Turn the timer control dial to either a time between 1-15 minutes or to the hold setting
Cooking uneven	Check that the all elements are glowing when switches are on and timer in the on position.	If one of the elements is not working. Contact and engineer.



Service Information

This appliance should be routinely serviced to prolong its lifetime. Parry recommends that the appliance is serviced every 12 months by a Parry authorised engineer. Failure to service your product within the initial 12 month warranty period will cause the 24 month warranty to become void.

If the supply cord becomes damaged, it must be replaced by the manufacturer, it's service agent, or a similarly qualified person.

Enhanced 2 Years Warranty

Parry Catering (Midlands) Ltd offer an enhanced warranty of two years (including parts and labour) on all of the Parry manufactured products. To take advantage of this you should register your warranty by logging onto the company website and filling out our simple form.

www.parry.co.uk/the-parry-warranty

If you have any issues with your product and wish to request a warranty call you can contact our friendly team who will organize a Parry approved service engineer to attend and fix your problem.

All warranty requests can be sent to warranty@parry.co.uk alternatively call our warranty department for technical assistance on **01332 875544**





Wiring Diagram

CAS Wiring Diagram

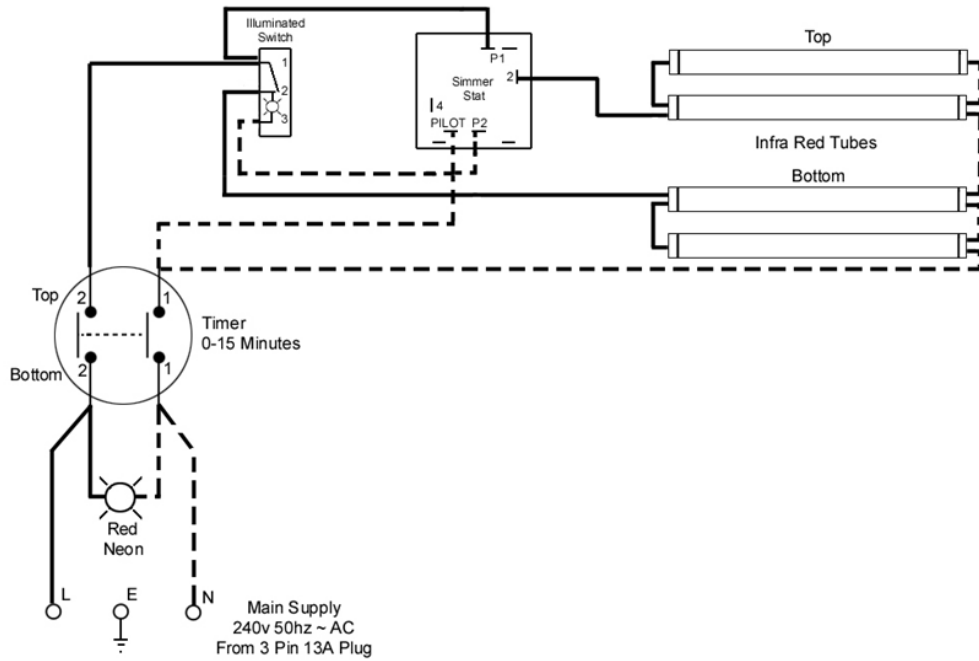

CPG Wiring Diagram

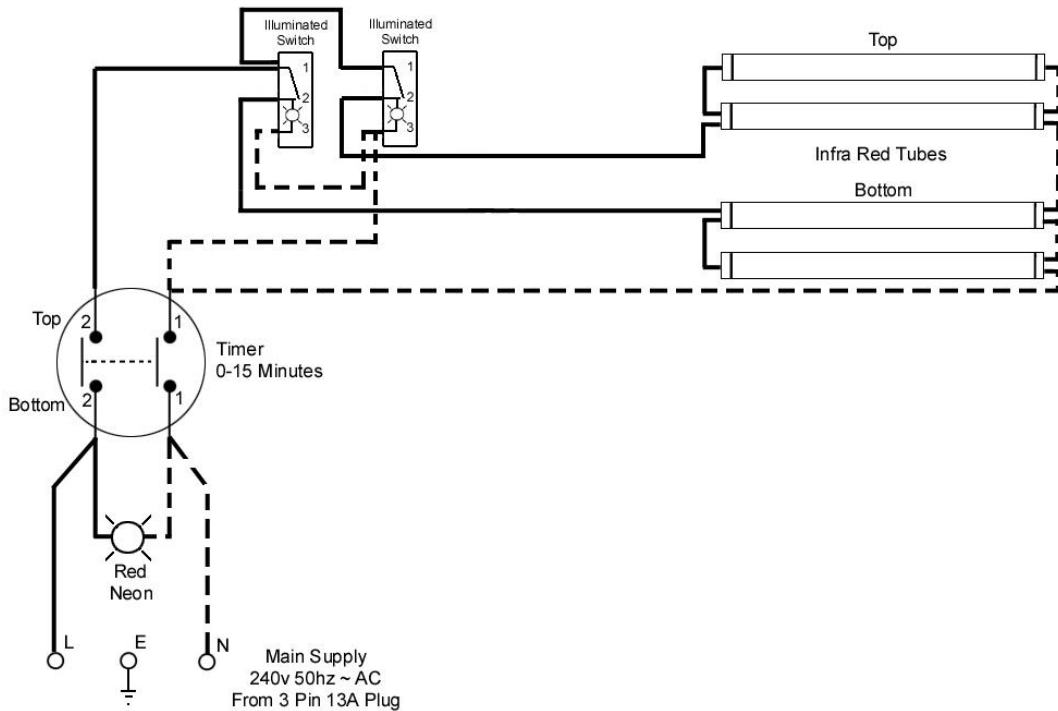



Exploded View

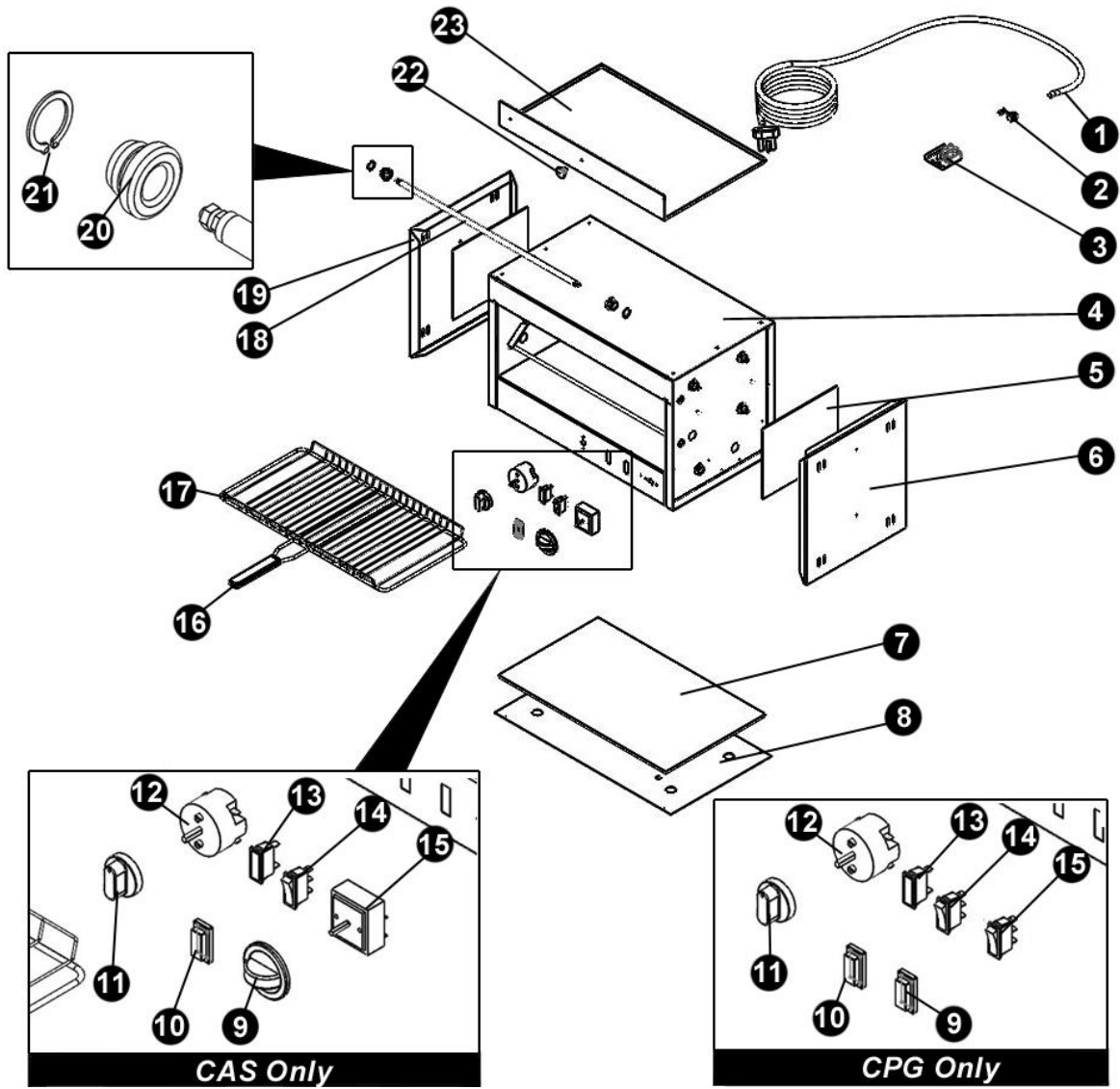



Parts List

Part Number	Description	Code
1	Mains Lead	MAINSLEAD
2	BLACK NYLON BUSHING SR6P30CEE	BUSR06003
3	Terminal Block	TERMBRKT1
4	*Body	CAS = *No Code CPG = *No Code
5	Filamic Board	FILM005116 <small>(Please request for CAS/CPG at time of order)</small>
6	*RH Side Panel	*No Code
7	LTI Insulation Board	ASPC06457
8	*Base	*No Code
9	CAS = Control Knob CPG = Switch Cover	CAS = KNOBTYPED CPG = LE25COVER
10	Switch Cover	LE25COVER
11	Timer Knob	<i>Part of item 12</i>
12	15m Switched Timer CW Knob and scale	TMER53015
13	Red Neon	LNRE06178
14	ON/OFF Switch	SWRE06165
15	CAS = Energy Regulator CPG = ON/OFF Switch	CAS = SATT37071 CPG = SWRE06165
16	Grill Rack Handle	HANDLEBASK
17	Grill Rack	TRSM00002
18	Infrared Heating Element (Per item)	ELIN00750
19	*LH Side Panel	*No Code
20	Insulation Bush	BUCE00099
21	Circlip	CRCL00089
22	Tray Knob	KNBK11680
23	*Crumb Tray	*No Code

*Metalwork Components



Warranty Information

The manufacturer's warranty is only valid in the UK mainland. Northern Ireland, Western Isles, Inner Hebrides and Islands are parts only warranty. Please be aware that the warranty starts from the date of purchase from Parry and not the sale or installation date of the equipment.

To be eligible for a 2 year warranty, products must be serviced at least once within the first 12 months of purchase.

All service calls will be carried out between 8am and 5pm, Monday to Friday.

Your warranty is invalid if your equipment has not been installed in accordance with the manufacturer's instructions. The misuse, alteration or unauthorised repairs of the equipment will also invalidate the warranty.

During the warranty period it is at Parry's discretion whether to repair or replace the equipment.

The warranty only applies if the equipment has been used in a professional manner following the manufacturer's instructions and maintenance guidelines.

The warranty covers defects in the material and component failure only. We are not liable for trading loss, loss of perishable items, water damage or loss due to injury or fire damage.

Please ensure you have referred to the manufacturer's instruction before placing a warranty call.

Contact our warranty department on **01332 875544** for technical assistance.











Please have your model number ready before calling.

All warranty requests must be submitted to warranty@parry.co.uk.

Failure to pay any warranty charges will result in your warranty being put on hold until the bill has been settled. Any issues regarding the raised charges should be put in writing to our warranty department for further investigation.

Register your product by visiting our website www.parry.co.uk

Not covered under warranty

-  Fault due to incorrect installation, poor maintenance or equipment abuse.
-  Resetting of equipment or circuit breakers.
-  Faulty electrics – e.g. customer's plug socket, plug, wiring, junction box fault, wrong fuse.
-  Products must be serviced within the first 12 months to be eligible for the 2 year warranty
-  Product not covered by warranty if combustible materials have been used, e.g. plastic trays.
-  Foil used on racks, blockages and lime scale issues.
-  Failure to grant access for pre-arranged service call.
-  Equipment that has been set up or used incorrectly e.g. dishwasher detergents, levelling and setting up of doors on a six burner cooker.
-  Excessive carbon build-up on griddle plates or overuse of lava rock on chargrills. (Recommended use by Parry no more than 2kg.)
-  All of the above points are not covered by warranty and any costs incurred, because of the above, will be forwarded to the parties responsible for placing the call.



Disposal & Recycling

This appliance is marked according to the European Directive 2002/96/EC on Waste Electrical and Electronic Equipment (WEEE).

By ensuring this product is disposed of correctly, you will help prevent potential negative consequences for the environment and human health which could otherwise be caused by inappropriate waste handling of this product.

A symbol on the product, or on the documents accompanying the product, indicates that

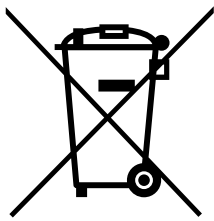

this appliance may not be treated as household waste. Instead it should be handed over to the applicable collection point for the recycling of electrical and electronic equipment.

Disposal must be carried out in accordance with local environmental regulations for waste disposal.





For more detailed information about treatment, recovery and recycling of this product, please contact your local city office, your household waste disposal service or the shop where you purchased the product.

Parry Catering recognises our obligations to the EU DIRECTIVE covering the waste disposal of electrical and electronic equipment (WEEE). Parry Catering are committed to this policy in order to help conserve the environment.

At the end of this unit's life you **MUST** dispose of it in an approved manner. You **MUST** not discard the unit or place it in the refuse bin.

You have several options:

-  Take the unit to an approved WEEE scheme company, there will be one in your area.
-  Take the unit to an approved waste disposal site; many sites are managed by your local authority.
-  Contact the units manufacturer, importer or their agent; the contact details will be on the unit.

There will probably be a charge for this service which will depend on the physical size and location of the unit. You will be given a collection price for a curb side collection based on commercial rates prevailing at the time.

It should be noted that the unit to be collected should be suitably packed and sealed to prevent dangerous gases and fluids from escaping. The condition of the unit must also be clean to comply with health and safety regulations.