

G350/11 and G350/12 FREESTANDING FRYERS

USERS INSTRUCTIONS



- SECTION 1 - GENERAL DESCRIPTION**
- SECTION 2 - LIGHTING and OPERATIONS**
- SECTION 3 - COOKING HINTS**
- SECTION 4 - CLEANING and MAINTENANCE**

These Appliances have been CE-marked on the basis of compliance with the Gas Appliance Directive, for the Countries, Gas Types and Pressures as stated on the Data Plate.

These Appliances **MUST BE** installed by a competent person in compliance with the **INSTALLATION AND SERVICING INSTRUCTIONS** and National Regulations in force at the time. Particular attention **MUST** be paid to the following:

Gas Safety (Installation & Use) Regulations
Health and Safety at Work Act

Furthermore, if a need arises to convert the Appliance for use with another gas, a competent person must be consulted. Those parts which have been protected by the manufacturer **MUST NOT** be adjusted by the User.

Users should be conversant with the appropriate provisions of the Fire Precautions Act and the requirements of the Gas Safety Regulations. In particular the need for regular servicing by a competent person to ensure the continued safe and efficient performance of the Appliance.

**WARNING - TO PREVENT SHOCKS, ALL APPLIANCES WHETHER
GAS OR ELECTRIC, MUST BE EARTHED**

Upon receipt of the User's Instruction manual, the installer should instruct the responsible person(s) of the correct operation and maintenance of the Appliance. Particular emphasis should be made with regard to safe operation of the drain valve.

This equipment is **ONLY FOR PROFESSIONAL USE**, and shall be operated by **QUALIFIED** persons. It is the responsibility of the Supervisor or equivalent to ensure that users wear **SUITABLE PROTECTIVE CLOTHING** and to draw attention to the fact that, some parts will, by necessity, become **VERY HOT** and will cause burns if touched accidentally.



WEEE Directive Registration No. WEE/DC0059TT/PRO

At end of unit life, dispose of appliance and any replacement parts in a safe manner, via a licensed waste handler. Units are designed to be dismantled easily and recycling of all material is encouraged whenever practicable.

Falcon Foodservice Equipment

HEAD OFFICE AND WORKS

Wallace View, Hillfoots Road, Stirling. FK9 5PY. Scotland.

SERVICELINE CONTACT: 01438 363 000 f: 01438 369 900

T100688 Ref 3

SECTION 1 - GENERAL DESCRIPTION

The G350/11 and G350/12 are freestanding gas-heated fryer units of the Falcon 350 Series, being 350mm and 700mm wide respectively. All individual units comprising the Series are of modular dimensions, enabling suites of appliances to be installed in a matching line. Counter mounted units can be installed either on a table or similar, or alternatively on purpose-made stands, supplied by Falcon, which ensure perfect matching of hob-heights when installed together with floor-standing appliances.

The G350/11 is a single-pan fryer 350mm wide is heated by a single burner of 11.8kW heat input. The G350/12 is the double pan version, being 700mm wide, each pan being similar to that on the G350/11 unit.

Both versions are constructed with the controls, drain valve etc. concealed within the cabinet which is fitted with a hinged door.

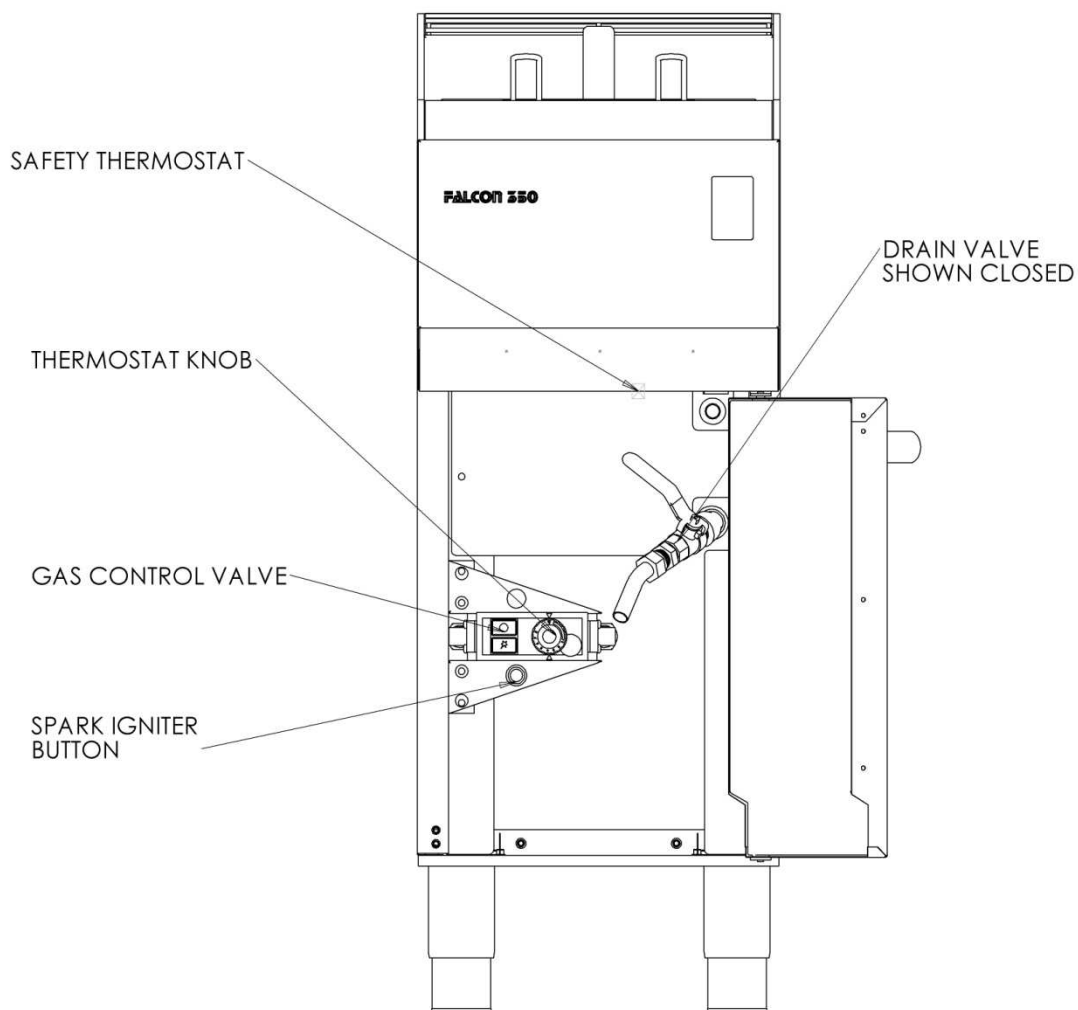

FIGURE 1

The fryers are equipped with a multifunctional gas control, incorporating on/off tap, thermostat and flame-failure device. The burner is lit by means of a pilot, which is ignited by a push-button.

SECTION 2 - LIGHTING and OPERATIONS

Warning

If the pilot be extinguished either intentionally or unintentionally, no attempt to re-light the gas should be made until at least three minutes have elapsed.

The procedure for lighting the burner is as follows (Refer to Figures 1 & 2):

- a) Ensure that the pan contains oil up to the level mark embossed on the rear wall of the pan.
- b) Open the cabinet door, giving access to the controls.
- c) Refer to Figure 2, and turn the thermostat knob clockwise to the ignition position
- d) Depress the rectangular igniter button marked and hold it in.
- e) Depress the spark igniter button and observe that the pilot lights. If it does not light immediately, repeatedly depress and release the spark igniter button until it does.
- f) Hold the ignition button in for a further 20 seconds, then release the button. If the pilot goes out, wait for three minutes, then repeat from (iv).
- g) When the pilot is established, turn the thermostat knob anti-clockwise to the desired temperature setting - No 8 is the maximum, producing an oil temperature of 190°C.

To Shut The Fryer OFF

For Short Periods (e.g. when unattended.)

To turn off the main burner, but leaving the pilot lit, turn the thermostat knob clockwise to the ignition position.

For Long Periods (e.g. overnight)

To turn off the main burner and the pilot, push in the OFF button.

The fryer pans are equipped with safety thermostats, which shut off the gas in the event of the oil becoming overheated as a result of failure of the control thermostat. Should this occur, push reset button in using a thin shafted screwdriver.

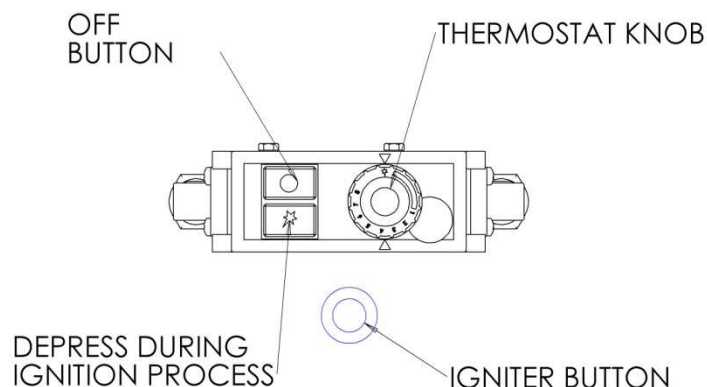

figure 2 - Gas Control Valve

SECTION 3 - COOKING HINTS

Important

CAUTION - These fryers give optimum performance when a good quality vegetable oil is used as the frying medium. Nevertheless, favourable results can be obtained from cooking fats provided the following procedures are adhered to.

- a) Never operate the thermostat above the smoke point of the chosen cooking fat; e.g. some drippings can have a smoke point as low as 170°C. Reputable cooking fat manufacturers supply this information.
- b) To prevent localised overheating taking place around electric elements, or hot external walls of the pan, fats should be broken up into small pieces when charging the pan initially, or topping up to the working level, and the thermostat should not be set above 120°C until the fat is in a liquid state.

From cold, the fryer takes approximately 12 to 15 minutes to reach maximum temperature (No 8 on the control corresponds to 190°C).

Oil capacities are:

12ltrs for the G350/11

24ltrs for the G350/12

Frying Chips

Chip potatoes can be fried by the following methods:

Raw to Finish

Set the thermostat to 8 and load each basket with 0.8kg (1 3/4 lbs) of raw chips and fry for 4 to 5 minutes according to size of chip, and variety of potato.

Blanching

This method can be used when large quantities of chips are required at peak periods, and consists of pre-frying at a reduced temperature, say 6, using basket loads of 0.8kg (1 3/4 lbs). Cook initially for about 4mins. Finishing off should be carried out within 3 hours of blanching at a thermostat setting of 8, cooking for 1 to 2 minutes only. Serve immediately and avoid further storage if possible.

Frying Fish

Fish is best fried on the base grid, i.e. not in the baskets. When cooked, remove with a fish lifter. The recommended thermostat settings are 6 or 7, the time varying according to the type and size of fish.

Other Foods

Each food suitable for deep frying has a particular cooking temperature at which best results are obtained. The following list gives a representative selection of foods, together with recommended thermostat settings.

These may, of course, be varied to suit individual tastes and requirements.

Fried Bread	No 8
Doughnuts	No 8
Fishcakes	No 7
Chicken	No 7
Sausages	No 6
Scampi	No 6
Meat (chops etc)	No 6

SECTION 4 - CLEANING AND MAINTENANCE

Regular cleaning is important on an appliance of this nature, and cleanliness can be encouraged by regular changing of the frying medium.

Allow the oil, or other frying medium, to cool to a safe temperature before draining the fryer. To drain the pan, turn drain valve (Figure 1) to the open position (lever in line with pipe) having placed a suitable container underneath the drain pipe.

After draining the pan, wipe the interior, and remove all food particles and other debris. For thorough cleaning, fill the pan to the level mark with water and detergent solution, and bring to boil. Turn off the gas; drain off the water; then rinse thoroughly; and dry. Ensure that the drain valve is in the closed position.

Important Note

Do not use proprietary cleaners, especially those which may have a high caustic content, on the vitreous enamelled surfaces of this unit (i.e. facia panel, drip tray, flue upstand).

This is particularly important when the appliance is hot. Such cleaners can cause serious damage or discoloration to the enamel finish, and only a soap or detergent solution should be used.