



P8P3 - Panther 800
Series Free-standing Hot
Cupboard - Plain Top - W
1230 mm - 1.5 kW

Helping to cater in demanding environments such as cafeterias, canteens and restaurants, the Panther 800 Series Hot Cupboard is perfect for plating and garnishing and as a pass to front of house staff, while it also provides extra workspace or can be used as a mobile workstation.

- ✔ Helping to cater in demanding environments such as cafeterias, canteens and restaurants
- ✔ Fan assisted hot cupboard provides even heat distribution, fast heat up and recovery times, and lower energy usage. Four shelf positions allow adjustment to meet individual needs.
- ✔ Fully 1/1 GN compatible hot cupboard for operational efficiency. Units available to take 3 x 1/1 GN containers up to 150mm deep.
- ✔ Accurate digital electronic control of the hot cupboard temperature, adjustable between 20 and 99 degrees C, ensures compliance with food hygiene regulations
- ✔ Double skinned construction provides efficient heat retention and a cool to touch exterior - safe and energy efficient. Removable doors and shelves allow access to the fully stainless steel interior for easy cleaning
- ✔ Supplied with two heavy duty multi-section chrome plated rod shelves capable of taking the heaviest loads

Specifications

Summary		Power and Performance	
Range Name	Panther	Total Power kW	1.5
Power Type	Electric	Temperature Range °C	20 - 99
Unit Type	Free-standing	IP Rating	IP24
Available in UK Only	No	Plate Capacity	316
UK Warranty	2 Years Parts and Labour Warranty	Temperature Control	Electronic
Export Warranty	Contact your local dealer		
GTIN Code	5056105103554		

Key Specifications		Weights and Dimensions	
Number of Shelves included	2	Unit Height (External) mm	900
Number of Shelf Positions	4	Unit Width (External) mm	1205
Heated Base	Yes	Unit Depth (External) mm	850
Heated Gantry	No	Height (Internal) mm	432
Static or Mobile	Mobile	Width (Internal) mm	1020
		Depth (Internal) mm	512
		Shelf Dimensions Width mm	980
		Shelf Dimensions Depth mm	512
		Net Weight Kg	113

Supply Connections		Shipping	
Requires Installation	No	Packed Weight Kg	133
Requires Electrical Supply	Yes	Packed Height cm	110
UK 3 Pin Plug	Yes	Packed Width cm	123
Requires Hardwiring	No	Packed Depth cm	90
Electrical Supply Rating Watts	1,500		
Single Phase Amps	6.5		
Single Phase Voltage	230		

Available Options

Overshelf or Gantry	
PG3A	Ambient Gantry
PG3H	Heated Gantry
PS3A1	1 x Ambient Overshelf
PS3A2	2 x Ambient Overshelves
PS3A3	3 x Ambient Overshelves
PS3H1	1 x Heated Overshelf
PS3H2	2 x Heated Overshelves
PS3H3	3 x Heated Overshelves
Door Locks	
PDL3	Lockable Door
Corner Guards	
PCG	Corner Guards [Set of Four]
Trayslides	
PTS3	Tray Slide
Legs/Castors	
PLK	Legs

Available Accessories

PLK/S	PANTHER LEG KIT FOR CONVERSION IN THE FIELD
-------	---

Technical Picture

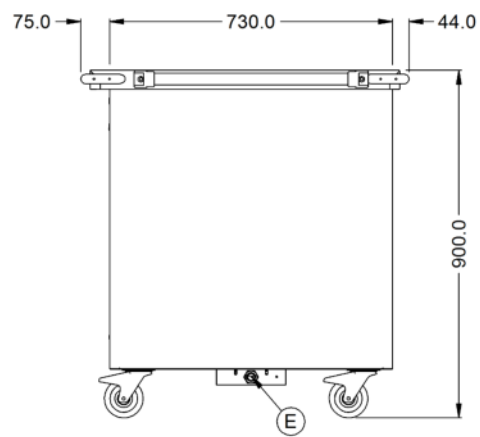
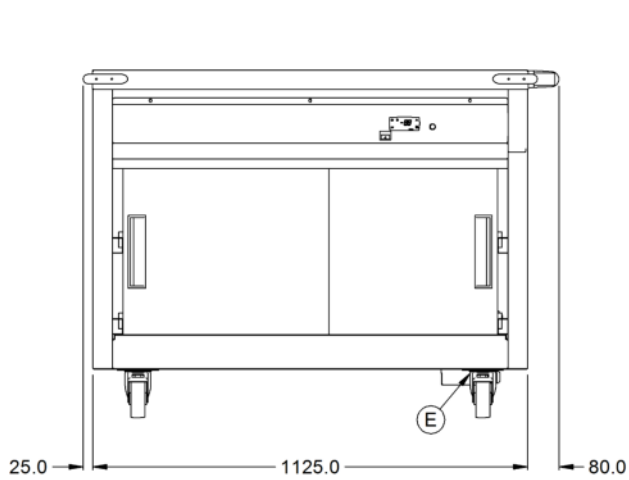

Lincat Limited

Whisby Road,
Lincoln, LN6 3QZ,
United Kingdom

Company No: 2175448

A member company of



Customer Care

Tel: +44 1522 875500
Email: care@lincat.co.uk

Export Customers

Tel: +44 1522 503250
Email: export@lincat.co.uk

Opening Hours

Monday – Friday:
8.30am – 5pm