



Please read and comply with these original instructions prior to the initial operation of your appliance and store them for later use or subsequent owners.

Contents

Device elements	EN	1
Safety instructions	EN	1
Proper use	EN	2
Safety Devices	EN	2
Environmental protection	EN	2
Before Startup	EN	3
Start up	EN	3
Operation	EN	4
Transport	EN	5
Storage	EN	5
Maintenance and care	EN	5
Troubleshooting	EN	6
Accessories and Spare Parts . .	EN	6
Warranty	EN	6
EC Declaration of Conformity . .	EN	7
Technical specifications	EN	8

Device elements

Please unfold the front picture side

- 1 Nozzle screws
- 2 Nozzle
- 3 Spray lance
- 4 Trigger gun
- 5 Safety lever
- 6 Lever for trigger gun
- 7 High pressure hose
- 8 Push handle, top (extended)
- 9 Push handle, bottom (slid in)
- 10 Holder for storage of a nozzle with screw connection or a surface cleaner**
- 11 Nozzle rack for triple nozzle**
- 12 Recessed grip
- 13 Nameplate
- 14 Skid
- 15 High pressure connection
- 16 Wheel
- 17 Nozzle rack for rotor nozzle (rotor nozzle is only included in the scope of delivery with model HD...Plus)
- 18 Spray lance holder with clamping, for transportation
- 19 Sieve

- 20 Water connection
 - 21 Quiver for spray lance
 - 22 Power switch
 - 23 Cable clamp
 - 24 Carrying handle
 - 25 Spray lance holder without clamping
 - 26 Rubber band
 - 27 Storage compartment for hoses
- ** not included in the scope of delivery

Colour coding

- The operating elements for the cleaning process are yellow.

Safety instructions

- Before first start-up it is definitely necessary to read the operating instructions and safety indications Nr. 5.951-949.0!
- Please follow the national rules and regulations for fluid spray jets of the respective country.
- Please follow the national rules and regulations for accident prevention of the respective country. Fluid spray jets must be tested regularly and the results of these tests must be documented in writing.

Hazard levels

△ DANGER

Pointer to immediate danger, which leads to severe injuries or death.

△ WARNING

Pointer to a possibly dangerous situation, which can lead to severe injuries or death.

△ CAUTION

Pointer to a possibly dangerous situation, which can lead to minor injuries.

ATTENTION

Pointer to a possibly dangerous situation, which can lead to property damage.

Symbols on the machine

High-pressure jets can be dangerous if improperly used. The jet may not be directed at persons, animals, live electrical equipment or at the appliance itself.



According to applicable regulations, the appliance must never be used on the drinking water net without a system separator. A suitable system separator by KÄRCHER or alternatively a system separator according to EN 12729 type BA must be used.



Water that was flowing through a system separator is considered non-drinkable.

Proper use

Use this high pressure cleaner exclusively for

- for cleaning with high-pressure jet (e.g. cleaning of facades, terraces, gardening tools).

With optional accessories detergent can be added.

For stubborn soiling we recommend the use of a rotor nozzle (only included in the scope of delivery with model HD...Plus)

Quality requirements for water:

ATTENTION

Only clean water may be used as high pressure medium. Impurities will lead to increased wear and tear or formation of deposits in the appliance.

If recycled water is used, the following limit values must not be exceeded.

pH value	6,5...9,5
electrical conductivity *	Conductivity fresh water +1200 µS/cm
settleable solids **	< 0,5 mg/l
total suspended solids ***	< 50 mg/l
Hydrocarbons	< 20 mg/l
Chloride	< 300 mg/l
Sulphate	< 240 mg/l
Calcium	< 200 mg/l

Total hardness	< 28 °dH < 50 °TH < 500 ppm (mg CaCO ₃ /l)
Iron	< 0,5 mg/l
Manganese	< 0,05 mg/l
Copper	< 2 mg/l
Active chloride	< 0,3 mg/l
free of bad odours	
* Maximum total	2000 µS/cm
** Test volume	1 l, settling time 30 min
*** no abrasive substances	



Safety Devices

Safety devices serve for the protection of the user and must not be put out of operation or bypassed with respect to their function.

Pressure switch

If the lever on the trigger gun is released the pressure switch turns off the pump, the high pressure jet is stopped. If the lever is pulled the pump is turned on again.

Environmental protection

	The packaging material can be recycled. Please do not throw the packaging material into household waste; please send it for recycling.
	Old appliances contain valuable materials that can be recycled; these should be sent for recycling. Batteries, oil, and similar substances must not enter the environment. Please dispose of your old appliances using appropriate collection systems.

Notes about the ingredients (REACH)

You will find current information about the ingredients at:

www.kaercher.com/REACH

Before Startup

Attaching the Accessories

- Install nozzle with nozzle screw at the spray lance.
- Connect spray lance to trigger gun.
- Fasten the high pressure hose to the high pressure connection.

Start up

Electrical connection

⚠ DANGER

Danger of injury by electric shock.

- *It is imperative to connect the appliance to the electric mains by means of a plug. It is forbidden to permanently connect the appliance to the power supply. The plug serves for the disconnection from the mains.*
- *The plug and coupling of the extension cable used must be watertight.*
- *Use an extension cable with protective earth conductor (protection class 1) and an adequate cross section (see "Technical data") and fully uncoil it from the cable drum.*

For connection values, see type plate/technical data.

- Unwind the mains cable and place it on the floor.
- Insert the mains plug into a socket.

Water connection

Connection to the water supply

⚠ WARNING

Observe regulations of water supplier.

According to applicable regulations, the appliance must never be used on the drinking water net without a system separator. A suitable system separator by KÄRCHER or alternatively a system separator according to EN 12729 type BA must be used.

Water that was flowing through a system separator is considered non-drinkable.

⚠ CAUTION

Always connect the system separator to the water supply, never directly to the appliance!

For connection values refer to technical specifications

- Connect the supply hose (min. length 7.5 m, minimum diameter 1/2") to the water connection point of the machine and at the water supply point (for e.g. a tap).

Note:

The supply hose is not included.

- Open the water supply.

Drawing in water from open reservoirs

- Screw the suction hose with filter (optional accessory) to the water connection.
- Appliance ventilation:
Unscrew the nozzle from the spray lance.
Switch on the appliance and let it run until the water exiting is bubble-free.
Let the appliance run for 10 seconds – then switch off the appliance switch.
Repeat the procedure several times.
- Switch off the appliance and fit the nozzle again.



Operation

⚠ DANGER

Risk of explosion!

Do not spray flammable liquids.

If the appliance is used in hazardous areas (e.g. filling stations) the corresponding safety regulations must be observed.

⚠ CAUTION

Environmental damage. Clean motors at places with a corresponding oil separator only.

⚠ DANGER

Long hours of using the appliance can cause circulation problems in the hands on account of vibrations.

It is not possible to specify a generally valid operation time, since this depends on several factors:

- Proneness to blood circulation deficiencies (cold, numb fingers).
- Low ambient temperature. Wear warm gloves to protect hands.
- A firm grip impedes blood circulation.
- Continuous operation is worse than an operation interrupted by pauses.

In case of regular, long-term operation of the device and in case of repeated occurrence of the symptoms (e.g. cold, numb fingers) please consult a physician.

Operation

The appliance can be operated in a vertical or horizontal position.

Note:

The appliance is equipped with a pressure switch. The motor starts up only when the lever of the pistol is pulled

- Set the appliance switch to "I".
- Unlock the trigger gun and pull the lever of the gun.

Interrupting operation

- Release the lever of the trigger gun; the device will switch off.
- Release again the lever of the trigger gun; the device will switch on again.

Turn off the appliance

- Set the appliance switch to "0".
- Disconnect the mains plug from the socket.
- Shut off water supply.
- Activate trigger gun until device is pressure-less.
- Press the safety lever of the trigger gun to secure the lever of the pistol against being released accidentally.

Storing the Appliance

- Place the spray lance with the trigger gun into the quiver for the spray lance and snap it into place in the spray lance holder.
- Wind the connection cable around the cable holder.
- Fasten the plug with the mounted clip.
- Slide in push handle.
- Wind up the high-pressure hose and hang it over the hose storage.

Frost protection

ATTENTION

Frost will destroy the not completely water drained device.

Store the appliance in a frost free area.

If you cannot store it in a frost-free place:

- Drain water.
- Pump in conventional frost protection agents through the appliance.

Note:

Use normal glycol-based anti-freezing agents for automobiles.

Observe handling instructions of the anti-freeze agent manufacturer.

- Operate device for max. 1 minute until the pump and conduits are empty.

Transport

⚠ CAUTION

Risk of injury and damage! Observe the weight of the appliance when you transport it.

- ➔ Hold the appliance at the carrying handle and the recessed grip for carrying it.
- ➔ When transporting in vehicles, secure the appliance according to the guidelines from slipping and tipping over.
- ➔ For transport over longer distances, pull out the push handle to the end position and drag the appliance behind you holding the push handle.
- ➔ In order to climb stairs, pull the appliance up step by step. The skids protect the casing from damage.

Holder for surface cleaner

- ➔ Attach the connecting piece of the surface cleaner to the holder on the high-pressure cleaner.
- ➔ Unscrew union nut.

Transport by crane

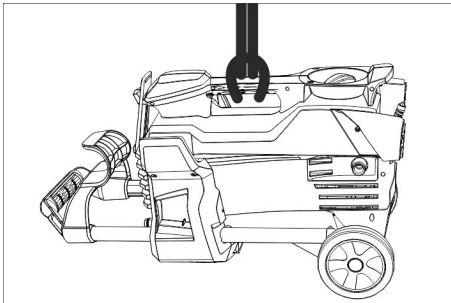

- ➔ Attach the lifting device to the carrying handle of the appliance.

Safety information about cranes

⚠ DANGER

Risk of injury due to machine dropping.

- Adhere to the local accident prevention guidelines and safety notes.
- Check the carrying handle for damage prior to every transportation by crane.
- Check the lifting unit for damage prior to each transport by crane.

- Only lift the appliance using the carrying handle.
- Do not use stop chains.
- Protect the lifting device from inadvertent load release.
- Remove spray lance with trigger gun, nozzles, surface cleaner and other loose objects prior to transportation by crane.
- Do not transport any articles on the appliance during the lifting process.
- The appliance must only be transported by properly trained crane personnel.
- Do not stand below the load.
- Ensure that no persons are present in the immediate vicinity of the crane.
- Do not leave the appliance on the crane unattended.

Storage

⚠ CAUTION

Risk of injury and damage! Note the weight of the appliance in case of storage.

This appliance must only be stored in interior rooms.

Maintenance and care

⚠ DANGER

Risk of injury by inadvertent startup of appliance and electrical shock.

First pull out the plug from the mains before carrying out any tasks on the machine.

Safety inspection/ maintenance contract

You can sign with your dealer a contract for regular safety inspection or even sign a maintenance contract. Please take advice on this matter.

Before each use

- ➔ Check connection cable for damages (risk of electrical shock); get the damaged connection cable replaced immediately by an authorised customer service person/ electrician.
- ➔ Check the high pressure hose for damages (risk of bursting).

Please arrange for the immediate exchange of a damaged high-pressure hose.

- Check appliance (pump) for leaks. 3 drops per minute are permitted and can come out from the lower side of the appliance. Call Customer Service if there is heavy leakage.

Weekly

- Clean the sieve in the water connection.

Clean the sieve in the water connection

- Take out sieve.
- Clean the sieve from the outside and rinse it.
- Insert sieve.

Troubleshooting

⚠ DANGER

Risk of injury by inadvertent startup of appliance and electrical shock.

- Prior to all work on the appliance, switch off the appliance and pull the power plug.
- Get the electrical components checked and repaired only by authorised customer service persons.
- Contact an authorised customer service person in case of problems not mentioned in this chapter or if you are in doubt or when you have been explicitly asked to do so.

Appliance is not running

- Check connection cable for damages.
- Check the supply voltage.
- If the appliance is overheated: Set the appliance switch to "0". Allow machine to cool down at least for 15 minutes. Set the appliance switch to "1".
- Call Customer Service in case of electrical defects.

Pressure does not build up in the appliance

- Check the nozzle size, install correct nozzle.
- Deaerate the appliance (see "Start-up")
- Clean the sieve in the water connection.
- Check water supply level (refer to technical data).
- Clean the nozzle.
- Replace the nozzle.
- Contact Customer Service if needed.

Pump leaky

3 drops of water per minute are permitted and can leak from the bottom of the appliance.

- With stronger leak, have device checked by customer service.

Pump is vibrating

- Check the water suction pipe for leaks.
- Deaerate the appliance (see "Start-up")
- Contact Customer Service if needed.

Accessories and Spare Parts

- Only use accessories and spare parts which have been approved by the manufacturer. The exclusive use of original accessories and original spare parts ensures that the appliance can be operated safely and trouble free.
- At the end of the operating instructions you will find a selected list of spare parts that are often required.
- For additional information about spare parts, please go to the Service section at www.kaercher.com.

Warranty

The warranty terms published by the relevant sales company are applicable in each country. We will repair potential failures of your appliance within the warranty period free of charge, provided that such failure is caused by faulty material or defects in manufacturing. In the event of a warranty claim please contact your dealer or the nearest authorized Customer Service centre. Please submit the proof of purchase.

EC Declaration of Conformity

We hereby declare that the machine described below complies with the relevant basic safety and health requirements of the EU Directives, both in its basic design and construction as well as in the version put into circulation by us. This declaration shall cease to be valid if the machine is modified without our prior approval.

Product: High pressure cleaner
Type: 1.520-xxx

Relevant EU Directives

2006/42/EC (+2009/127/EC)

2004/108/EC

2000/14/EC

2011/65/EU

Applied harmonized standards

EN 60335-1

EN 60335-2-79

EN 55014-1: 2006+A1: 2009+A2: 2011

EN 55014-2: 1997+A1: 2001+A2: 2008

EN 62233: 2008

EN 61000-3-2: 2006+A1: 2009+A2: 2009

EN 61000-3-3: 2013

EN 50581

Applied conformity evaluation method

2000/14/EC: Appendix V

Sound power level dB(A)

HD 5/11 P

Measured: 86

Guaranteed: 89

The undersigned act on behalf and under the power of attorney of the company management.

H. Jenner
CEO

S. Reiser
Head of Approbation

Authorised Documentation Representative
S. Reiser

Alfred Kärcher GmbH Co. KG

Alfred-Kärcher-Str. 28 - 40

71364 Winnenden (Germany)

Phone: +49 7195 14-0

Fax: +49 7195 14-2212

Winnenden, 2014/04/01

Technical specifications

Type	HD 5/11 P	HD 5/11 P	HD 5/11 P
	EU CH	AR CN	GB AU
Main Supply			
Voltage	V	230	220 230...240
Current type	Hz	50	
Connected load	kW	2,2	
Protection (slow, char. C)	A	10	
Type of protection	--	IPX5	
Extension cable, max. 30 m (Protection class 1)	mm ²	2,5	
Water connection			
Max. feed temperature	°C	60	
Min. feed volume	l/min	12	
Suck height from open container (20 °C)	m	0,5	
Max. feed pressure	MPa	1	
Performance data			
Working pressure	MPa	11	
Nozzle size	--	036	
Max. operating over-pressure	MPa	16	
Water flow rate	l/min	8,1	
Max. recoil force of trigger gun	N	20,4	
Values determined as per EN 60355-2-79			
Hand-arm vibration value	m/s ²	2,7	
Uncertainty K	m/s ²	0,8	
Sound pressure level L _{pA}	dB(A)	73	
Uncertainty K _{pA}	dB(A)	3	
Sound power level L _{WA} + Uncertainty K _{WA}	dB(A)	89	
Dimensions and weights			
Length	mm	351	
Width	mm	312	
Height	mm	904	
Typical operating weight	kg	20,5	