

Victor

Banquetline

Model Number: **BL100H1 one door**

Prepare & store hot food in advance of desired serving time.

The blown air heating system coupled with humidity tray keeps food in optimum condition until required.

Accepts 2 x GN1/1 containers - per level or maximum of 102 plated meals

Ideal for large scale catering

Product Features

- Four x 150mm heavy duty swivel castors two braked.
- Complete with 4 shelves and pair of supports
- All stainless steel construction
- Top mounted digital temperature control adjustable between 65 and 95 degrees centigrade.
- Integral water reservoir to cabinet base.
- Two side mounted push/pull bar
- All round protective bumpers

Extras

Gastronorm containers
Additional shelves and supports
Plate covers



Dimensions

External: 1070 x 760 x 1810mm
Internal: 770 x 610 x 1395mm

Electrical Connection

220V/240V, 1 phase, 50 Hz, 1.5kW loading, 6.3 Amps
Cable: 2 metres with 13 amp plug fitted

Capacity

42 x GN1/1 - 20mm deep
42 x GN1/1 - 40mm deep
28 x GN1/1 - 65mm deep
20 x GN1/1 - 100mm deep
16 x GN1/1 - 150mm deep
12 x GN1/1 - 200mm deep

(Containers not included)

*108 x 10" dia. plates with 60mm plate covers max.
(6 plates per level, 18 stacks)*

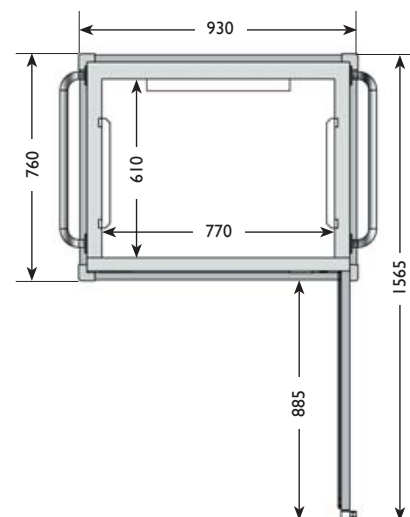
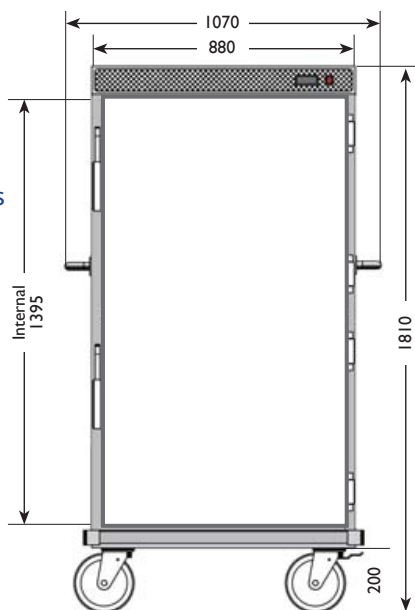

Victor Manufacturing Ltd

Lonsdale Works, Gibson Street,
Bradford BD3 9TF
tel: 01274 722125

email@victormanufacturing.co.uk

www.victoronline.co.uk