



# FOOD PROCESSOR-EMULSIFIER SKE-3

To chop, mash, mix, knead, emulsify any product in few seconds



## FEATURES AND BENEFITS

- ✓ Removable stainless steel bowl.
- ✓ Electronic control board.
- ✓ Electronic continuous variable speed control.
- ✓ Upper lid with hole to add liquids while operating.
- ✓ Equipped with safety micro switch.
- ✓ Special height blade shaft, which allow processing a larger quantity of liquids.

## INCLUDES

- ✓ Equipped with a set of standard serrated blades for general use.
- ✓ A scraper to obtain a more homogeneous final product

## SALES DESCRIPTION

Bowl capacity of 3 lt. (3 1/8 qt.)

DYNAMIC PREPARATION  
CUTTER-MIXERS & EMULSIFIERS



**www.sammic.co.uk**  
 Food Service Equipment Manufacturer  
 Unit 2, Trevanah Road  
 Troon Industrial Park  
 LE4 9LS - Leicester  
 uksales@sammic.com  
 Tel.: +44 0116 246 1900



Project	Date
Item	Qty
Approved	

product sheet  
updated 06/03/2018



# FOOD PROCESSOR-EMULSIFIER SKE-3

To chop, mash, mix, knead, emulsify any product in few seconds



## SPECIFICATIONS

- Bowl capacity: 3 l
- Bowl dimensions: Ø160 mm x 160 mm
- Total loading: 500 W
- Speed, min-max: 450 rpm - 3000 rpm
- External dimensions (WxDxH)**
  - ✓ Width: 240 mm
  - ✓ Depth: 370 mm
  - ✓ Height: 305 mm
- Net weight: 11.8 Kg
- Noise level (1m.): <70 dB(A)
- Background noise: 32 dB(A)
- Crated dimensions**
  - 395 x 315 x 360 mm
  - Gross weight: 13.5 Kg.

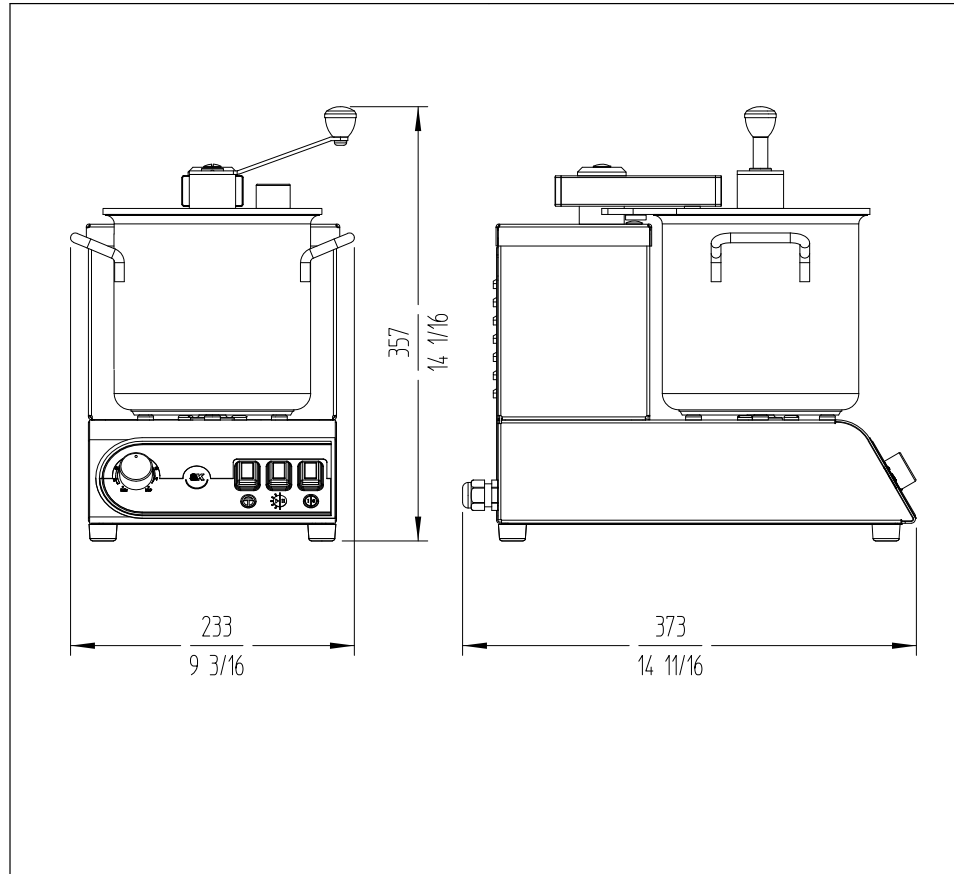

## AVAILABLE MODELS

1050086 Cutter-Emulsifier SKE-3 230/50-60/1

\* Ask for special versions availability

## ACCESSORIES

- Blades for SK/SKE
- Scraper set for SK/SKE

DYNAMIC PREPARATION  
CUTTER-MIXERS & EMULSIFIERS



**www.sammic.co.uk**  
**Food Service Equipment Manufacturer**  
 Unit 2, Trevanah Road  
 Troon Industrial Park  
 LE4 9LS - Leicester  
 uksales@sammic.com  
 Tel.: +44 0116 246 1900



Project	Date
Item	Qty
Approved	

product sheet  
updated 06/03/2018