



# FOOD-PROCESSOR - EMULSIFIER CKE-8

Capacity of the bowl: 8 lt. (8½ qt.). Variable speed appliance. Control panel with timer.



## FEATURES AND BENEFITS

- ✓ Specially designed to work with liquids.
- ✓ Cover design allows liquids to be added while in operation.
- ✓ Adjustable speed.
- ✓ Three modes of use: continuous, timer or pulse function.
- ✓ Unique “Cut&Mix” scraper included.
- ✓ Stainless steel construction and highest quality material, all suitable for contact with food.
- ✓ It consists of a variable speed motor block with a regular hopper and an 8 lt. (8½ qt.) food processor bowl complete with a hub with serrated blades.
- ✓ Strong, very easy to use and clean.
- ✓ High production. Ventilated motor allowing continuous use.
- ✓ User-friendly, waterproof led-lit control panel.
- ✓ Allows programming by time and includes a pulse switch
- ✓ Complete with “Cut&Mix” scraper.

## INCLUDES

- ✓ Motor block. hub with serrated blades.
- ✓ 8-liter bowl complete with a “Cut&Mix” scraper.

## SALES DESCRIPTION

Consists of a motor block and a 8 lt. (8½ qt.) bowl and a hub with serrated blades.

DYNAMIC PREPARATION  
CUTTER-MIXERS & EMULSIFIERS



[www.sammic.co.uk](http://www.sammic.co.uk)

Food Service Equipment Manufacturer  
Unit 2, Trevanah Road  
Troon Industrial Park  
LE4 9LS - Leicester  
[uksales@sammic.com](mailto:uksales@sammic.com)  
Tel.: +44 0116 246 1900



Project	Date
Item	Qty
Approved	

product sheet  
updated 06/03/2018



# FOOD-PROCESSOR - EMULSIFIER CKE-8

Capacity of the bowl: 8 lt. (8½ qt.). Variable speed appliance. Control panel with timer.



## SPECIFICATIONS

- Bowl capacity: 8 l
- Bowl dimensions: Ø240 mm x 240 mm
- Total loading: 1250 W
- Speed, min-max: 385 rpm - 3000 rpm

### External dimensions (WxDxH)

- ✓ Width: 284 mm
- ✓ Depth: 374 mm
- ✓ Height: 488 mm
- Net weight: 24.4 Kg

### Crated dimensions

450 x 360 x 580 mm

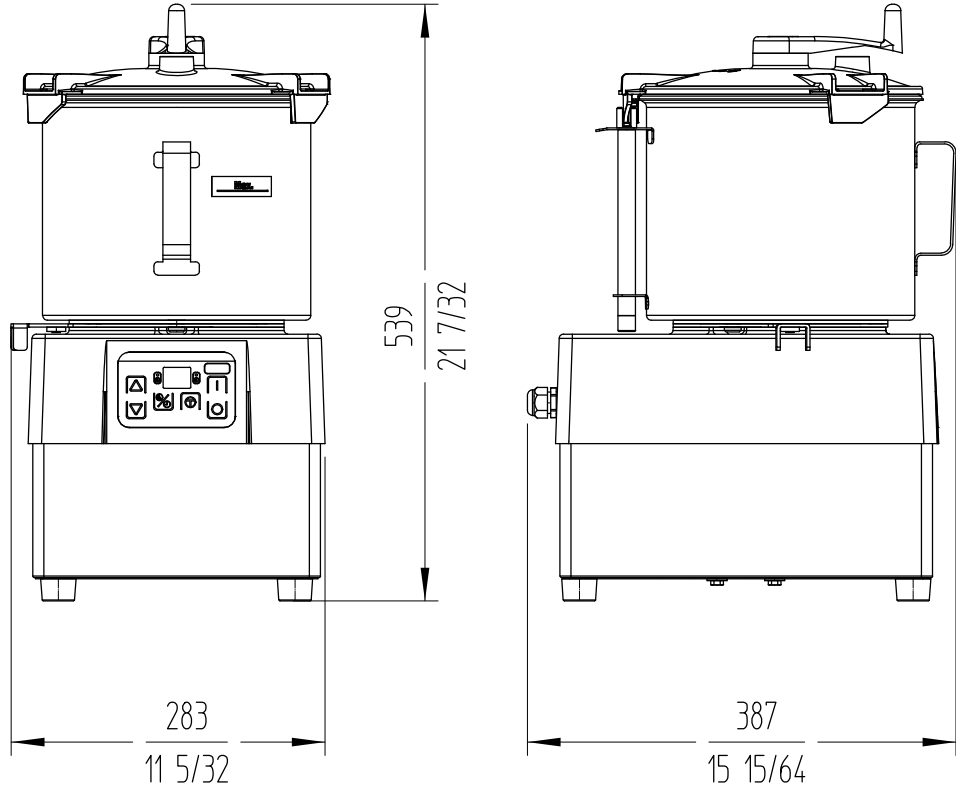

## AVAILABLE MODELS

1050160 Cutter-Emulsifier CKE-8 230/50-60/1

\* Ask for special versions availability

## ACCESSORIES

- Blades for CK/CKE
- "Cut&Mix" Scrapers CK/CKE

DYNAMIC PREPARATION  
CUTTER-MIXERS & EMULSIFIERS



[www.sammic.co.uk](http://www.sammic.co.uk)

Food Service Equipment Manufacturer

Unit 2, Trevanah Road  
Troon Industrial Park  
LE4 9LS - Leicester

[uksales@sammic.com](mailto:uksales@sammic.com)  
Tel.: +44 0116 246 1900



Project

Date

Item

Qty

Approved

product sheet  
updated 06/03/2018